

Thermoplastic Extruded Profiles

Habasit–Solutions in motion

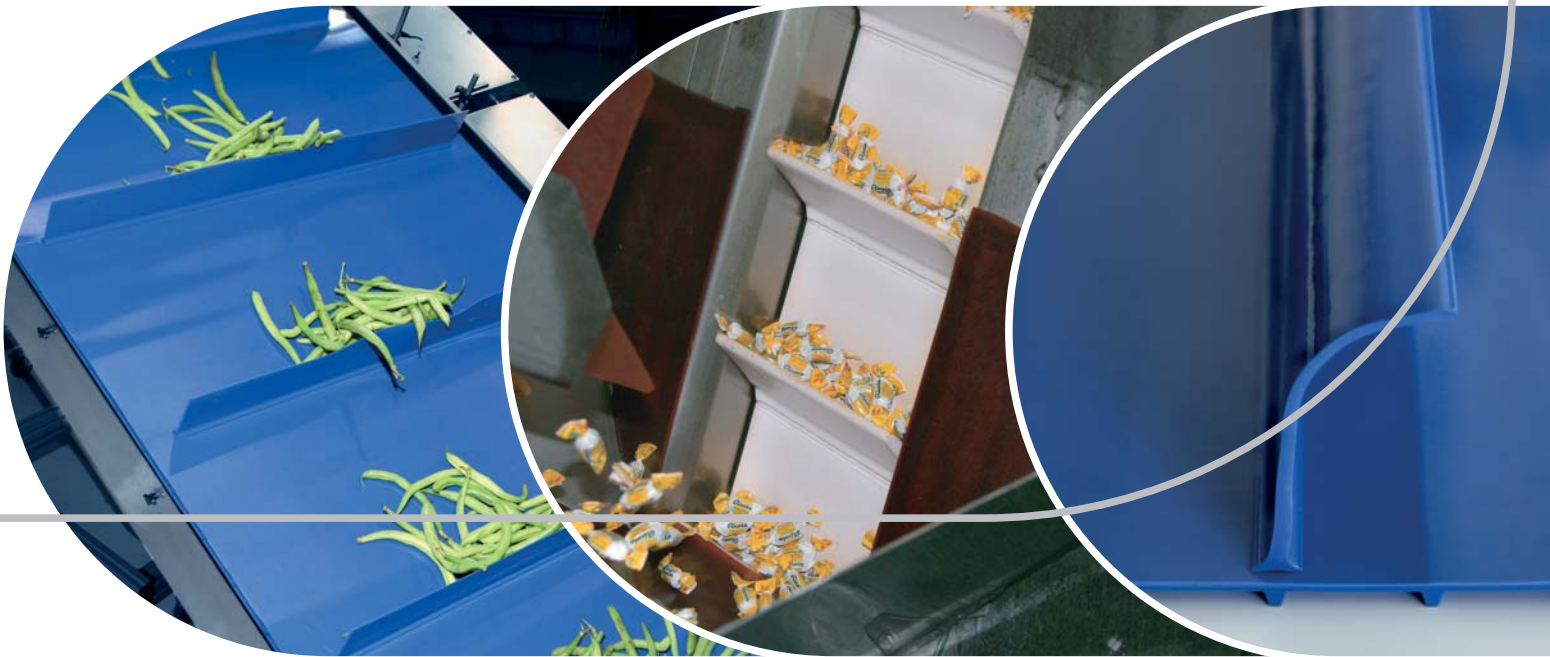

Accessories for conveyor belts	3
Key to Habasit profile nomenclature	4
Tracking guides	5
Cleats	8
Habibord (corrugated sidewalls)	11
Edge sealing profiles	12
Profiles for power turns	13
Habipur	14
Habicord	19
Habibblue	23
HabaSYNC® covers and tracking guides	27
Habasit Cleandrive™ accessories	29
Habiring	33
The Habasit Solution	35
Contacts	36

Product liability, application considerations

If the proper selection and application of Habasit products are not recommended by an authorized Habasit sales specialist, the selection and application of Habasit products, including the related area of product safety, are the responsibility of the customer. All indications / information are recommendations and believed to be reliable, but no representations, guarantees, or warranties of any kind are made as to their accuracy or suitability for particular applications. The data provided herein are based on laboratory work with small-scale test equipment, running at standard conditions, and do not necessarily match product performance in industrial use. New knowledge and experiences can lead to modifications and changes within a short time without prior notice. BECAUSE CONDITIONS OF USE ARE OUTSIDE OF HABASIT'S AND ITS AFFILIATED COMPANIES CONTROL, WE CANNOT ASSUME ANY LIABILITY CONCERNING THE SUITABILITY AND PROCESS ABILITY OF THE PRODUCTS MENTIONED HEREIN. THIS ALSO APPLIES TO PROCESS RESULTS / OUTPUT / MANUFACTURING GOODS AS WELL AS TO POSSIBLE DEFECTS, DAMAGES, CONSEQUENTIAL DAMAGES, AND FURTHER-REACHING CONSEQUENCES.

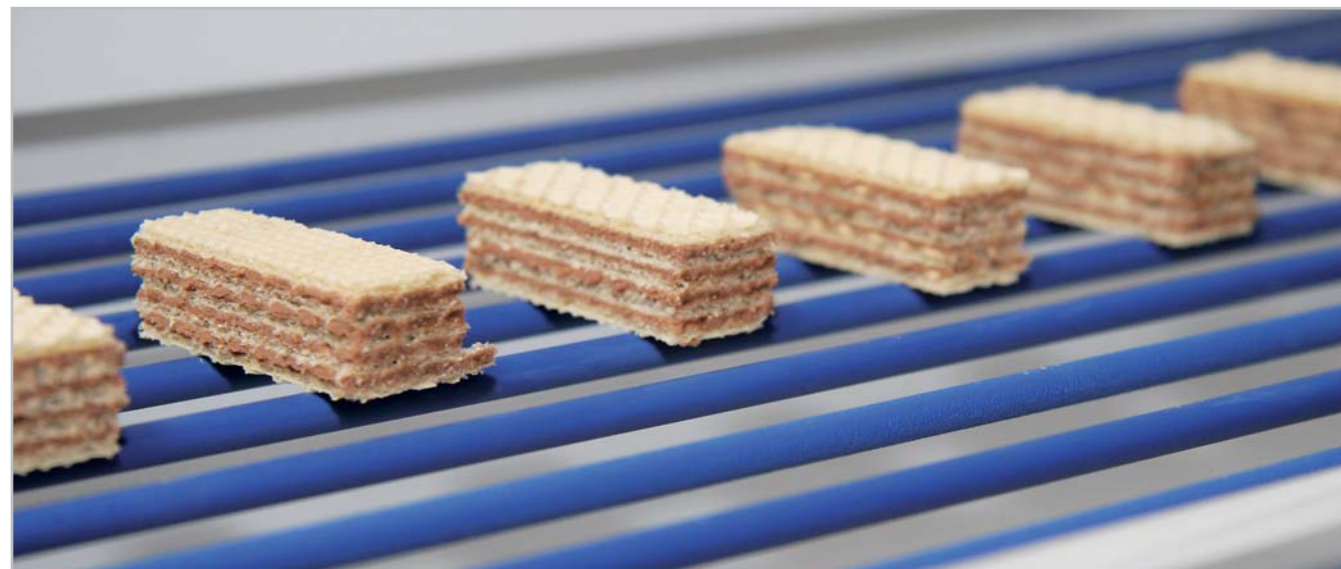

Not all products are standard stock items. Please check the availability with the Production Unit.

Habasit accessories range for conveyor belts includes: tracking guides, cleats, sidewalls and flat profiles for edge sealing.

Belts equipped with transversal profiles are mainly used for inclined applications; sidewalls are often used together with them to contain bulk goods on the sides of the belt. A wide range of profiles, different in shapes, colors, dimensions and shore hardness are available both in PVC and polyurethane.

Specific food grade TPU and PVC compounds with EU and FDA certifications have been developed for food contact applications.



Tracking guides

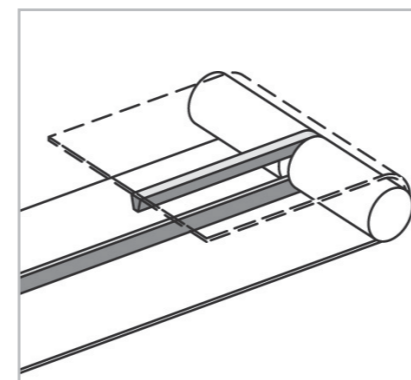

Cleats

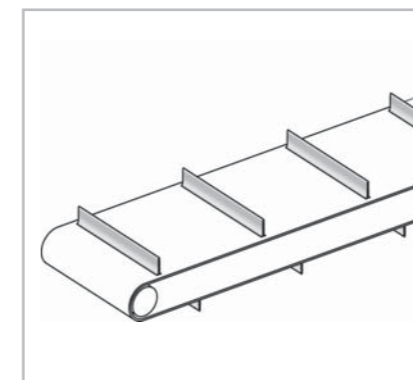

Sidewalls

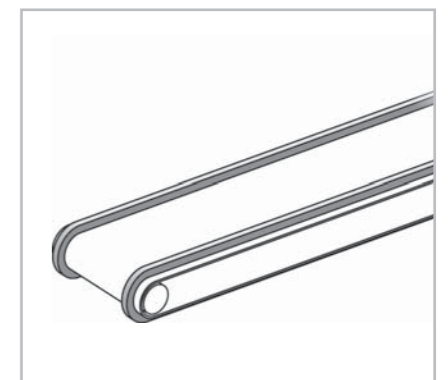

1st Code digit: Accessory Type

- A** Auxiliaries (e.g. flat profiles for edge sealing)
- P** Profile

2nd Code digit: Profile Type

- B** Bent (crancked tip)
- C** C-shaped
- N** Narrow based
- Q** Quadrangular-Rectangular
- R** Rounded
- T** T-Shaped
- S** Scoop
- V** V-shaped

3rd Code digit: Material

- C** TPO - range Cleanline (Habilene®)
- D** TPEE (polyester)
- F** TPU (food grade polyurethane)
- H** Hydrolysis resistant TPU
- R** PVC food grade and oil/grease resistant
- S** PVC standard (no food)
- V** PVC food grade

4th Code digit: Interruption

5th Code digit: Main dimension

6th Code digit: Color

- A** Anthracite
- B** Black
- C** Cobalt blue
- D** Dark green
- E** Beige
- G** Habasit green
- H** Honey (amber)
- I** Bluish
- K** Gold
- L** Light grey
- M** Grey
- N** Tan
- O** Orange
- P** Apple green
- R** Red
- S** Sky blue
- T** Transparent
- U** Brown
- W** White

7th-10th Code digit: Special Features

- N** Notched
- SN** Special notched
- H15** Antimicrobial additive
- Soft** TPU/PVC with lower hardness

P V F - 10 W SN

V - Shaped

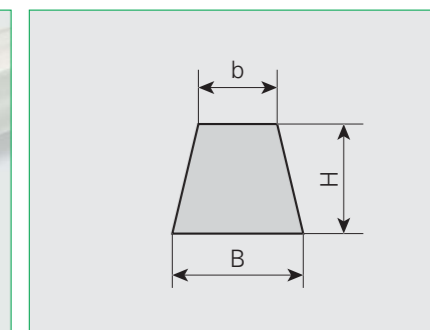

Code	Former code	Material	Color	B [mm]	H [mm]	b [mm]	Weight [kg/m]	Hardness [ShA]	Min. pulley diameters (longitudinal, conveyor side) [mm]	Min. pulley diameters (longitudinal, running side) [mm]	Food compliance	Packaging unit	Total length [m]
PVF-6W	PVF-6	TPU	white	6	4	4	0,026	85	50	40	EU/FDA	coil	200
PVF-8W	PVF-8	TPU	white	8	5	5	0,04	85	80	50	EU/FDA	coil	200
PVF-10W	PVF-10	TPU	white	10	6	6	0,06	85	110	60	EU/FDA	coil	200
PVF-13W	PVF-13	TPU	bianco	13	8	7	0,1	85	140	80	EU/FDA	coil	100
PVF-17W	PVF-17	TPU	white	17	11	9	0,18	85	160	110	EU/FDA	coil	50
PVF-8C	PVF-8XC	TPU	cobalt blue	8	5	5	0,04	85	80	50	EU/FDA	coil	200
PVF-10C	PVF-10XC	TPU	cobalt blue	10	6	6	0,06	85	110	60	EU/FDA	coil	200
PVF-13C	PVF-13XC	TPU	cobalt blue	13	8	7	0,1	85	140	80	EU/FDA	coil	100
PVF-10G	PVF-10/green	TPU	green	10	6	6	0,05	85	110	60	EU/FDA	coil	200
PVF-13G	PVF-13/green	TPU	green	13	8	7	0,1	85	140	80	EU/FDA	coil	100
PVF-17G	PVF-17/green	TPU	green	17	11	9	0,13	85	160	110	EU/FDA	coil	50
PVF-6T soft	PUR-6 soft	TPU soft	transparent	6	4	4	0,03	60	40	30	NO	coil	200
PVF-10 soft	PUR-10 soft	TPU soft	transparent	10	6	6	0,06	60	100	50	NO	coil	200
PVF-13 soft	PVF-13 soft	TPU soft	transparent	13	8	7	0,1	60	130	90	NO	coil	100
PVF-17T soft	PVF-17 soft	TPU soft	transparent	17	11	9	0,15	60	150	100	NO	coil	50
PVR-6W	PVV-6XW 09	PVC-FOOD	white	6	4	4	0,03	65	70	40	EU/FDA	coil	200
PVR-8W	PVV-8XW 09	PVC-FOOD	white	8	5	5	0,08	65	100	50	EU/FDA	coil	200
PVR-10W	PVV-10XW 09	PVC-FOOD	white	10	6	6	0,06	65	120	60	EU/FDA	coil	200
PVR13W	PVV-13XW 09	PVC-FOOD	white	13	8	7	0,1	65	150	80	EU/FDA	coil	100
PVR-17W	PVV-17XW 09	PVC-FOOD	white	17	11	9	0,15	65	180	120	EU/FDA	coil	50
PVS-6A	PVS-6	PVC	anthracite	6	4	4	0,03	65	70	40	NO	coil	200
PVS-8A	PVS-8	PVC	anthracite	8	5	5	0,08	65	100	50	NO	coil	200
PVS-10A	PVS-10	PVC	anthracite	10	6	6	0,06	65	120	60	NO	coil	200
PVS-13A	PVS-13	PVC	anthracite	13	8	7	0,1	65	150	80	NO	coil	100
PVS-17A	PVS-17	PVC	anthracite	17	11	9	0,15	65	180	120	NO	coil	50
PVS-22A	PVS-22	PVC	anthracite	22	14	14	0,145	65	220	170	NO	coil	50
PVS-30A	PVS-30	PVC	anthracite	30	16	18	0,59	65	250	200	NO	coil	25
PVS-6D	PVS-6/dg	PVC	dark green	6	4	4	0,03	65	70	40	NO	coil	200
PVS-8D	PVS-8/dg	PVC	dark green	8	5	5	0,08	65	100	50	NO	coil	200
PVS-10D	PVS-10/dg	PVC	dark green	10	6	6	0,06	65	120	60	NO	coil	200
PVS-13D	PVS-13/dg	PVC	dark green	13	8	7	0,1	65	150	80	NO	coil	100
PVS-17D	PVS-17/dg	PVC	dark green	17	11	9	0,15	65	180	120	NO	coil	50
PVS-10A soft	PVS-10 soft	PVC soft	anthracite	10	6	6	0,06	55	110	50	NO	coil	200
PVS-13A soft	PVS-13 soft	PVC soft	anthracite	13	8	7	0,1	55	140	70	NO	coil	100
PVS-17A soft	PVS-17 soft	PVC soft	anthracite	17	11	9	0,15	55	170	110	NO	coil	50
PVS-30A soft	PVS-30 soft	PVC soft	anthracite	30	16	18	0,59	55	230	180	NO	coil	25

Notched and Special notched tracking guides, with their special design, allow to use smaller pulley diameters than the whole V-shaped profiles. PUG and special PVC profiles can be used in applications that require larger but thinner tracking guides than standard V-shaped one.

Notched V-shaped



Code	Former code	Material	Color	B [mm]	H [mm]	b [mm]	Weight [kg/m]	Hardness [ShA]	Min. pulley diameters (longitudinal, conveyor side) [mm]	Min. pulley diameters (longitudinal, running side) [mm]	Food compliance	Packaging unit	Total length [m]
PVF-6W-N	PVF-6 notched	TPU	white	8	5	5	0,04	85	70	30	EU/FDA	coil	200
PVF-8W-N	PVF-8 notched	TPU	white	8	5	5	0,04	85	80	40	EU/FDA	coil	200
PVF-10W-N	PVF-10 notched	TPU	white	10	6	6	0,05	85	90	60	EU/FDA	coil	200
PVF-13W-N	PVF-13 notched	TPU	white	13	8	7	0,09	85	120	70	EU/FDA	coil	100
PVF-17W-N	PVF-17 notched	TPU	white	17	11	9	0,13	85	140	100	EU/FDA	coil	50
PVF-10G-N	PVF-10/green notched	TPU	green	10	6	6	0,06	85	90	50	EU/FDA	coil	200
PVF-17G-N	PVF-17/green notched	TPU	green	17	11	9	0,15	85	140	100	EU/FDA	coil	50
PVF-10T-N soft	PVF-10 soft notched	TPU soft	transparent	10	6	6	0,05	60	80	40	NO	coil	200
PVR-6W-N	PVV-6XW 09 notched	PVC-FOOD	white	6	4	4	0,03	65	60	30	EU/FDA	coil	200
PVR-8W-N	PVV-8XW 09 notched	PVC-FOOD	white	8	5	5	0,07	66	80	40	EU/FDA	coil	200
PVR-10W-N	PVV-10XW 09 notched	PVC-FOOD	white	10	6	6	0,06	65	100	50	EU/FDA	coil	200
PVR-13W-N	PVV-13XW 09 notched	PVC-FOOD	white	13	8	7	0,1	65	130	60	EU/FDA	coil	100
PVR-17W-N	PVV-17XW 09 notched	PVC-FOOD	white	17	11	9	0,15	65	160	100	EU/FDA	coil	50
PVS-8A-N	PVS-8 notched	PVC	anthracite	8	5	5	0,07	65	80	40	NO	coil	200
PVS-10A-N	PVS-10 notched	PVC	anthracite	10	6	6	0,06	65	100	50	NO	coil	200
PVS-13A-N	PVS-13 notched	PVC	anthracite	13	8	7	0,1	65	130	60	NO	coil	100
PVS-17A-N	PVS-17 notched	PVC	anthracite	17	11	9	0,15	65	160	100	NO	coil	50
PVS-22A-N	PVS-22 notched	PVC	anthracite	22	14	14	0,13	65	180	150	NO	coil	50
PVS-30A-N	PVS-30 notched	PVC	anthracite	30	16	18	0,59	65	220	160	NO	coil	25
PVS-6D-N	PVS-6/dg notched	PVC	dark green	6	4	4	0,03	65	60	30	NO	coil	200
PVS-8D-N	PVS-8/dg notched	PVC	dark green	8	5	5	0,07	65	80	40	NO	coil	200
PVS-10D-N	PVS-10/dg notched	PVC	dark green	10	6	6	0,06	65	100	50	NO	coil	200
PVS-13D-N	PVS-13/dg notched	PVC	dark green	13	8	7	0,1	65	130	60	NO	coil	100
PVS-17D-N	PVS-17/dg notched	PVC	dark green	17	11	9	0,15	65	160	100	NO	coil	50
PVS-10-N soft	PVS-10 soft notched	PVC soft	anthracite	10	6	6	0,06	55	90	40	NO	coil	200
PVS-13-N soft	PVS-13 soft notched	PVC soft	anthracite	13	8	7	0,1	55	120	50	NO	coil	100
PVS-17-N soft	PVS-17 soft notched	PVC soft	anthracite	17	11	9	0,15	55	140	80	NO	coil	50
PVS-30-N soft	PVS-30 soft notched	PVC soft	anthracite	30	16	18	0,59	55	200	150	NO	coil	25

Special notched V-shaped

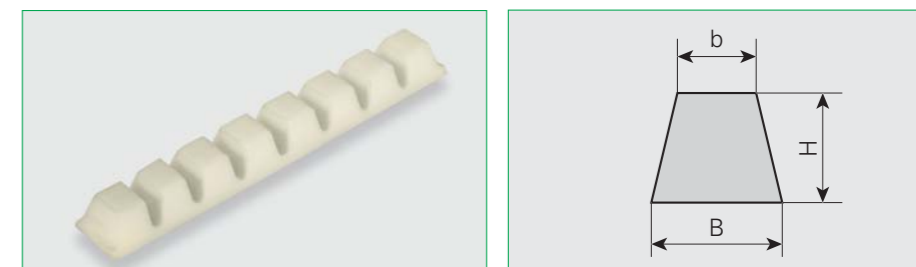

Code	Former code	Material	Color	B [mm]	H [mm]	b [mm]	Weight [kg/m]	Hardness [ShA]	Min. pulley diameters (longitudinal, conveyor side) [mm]	Min. pulley diameters (longitudinal, running side) [mm]	Food compliance	Packaging unit	Total length [m]
PVF-8W SN	PVF-8XW special notched	TPU	white	8	5	5	0,04	85	60	30	EU/FDA	coil	200
PVF-10W SN	PVF-10XW special notched	TPU	white	10	6	6	0,05	85	70	40	EU/FDA	coil	200
PVF-13W SN	PVF-13XW special notched	TPU	white	13	8	7	0,09	85	90	50	EU/FDA	coil	100
PVF-17W SN	PVF-17XW special notched	TPU	white	17	11	9	0,13	85	100	60	EU/FDA	coil	50

PUG

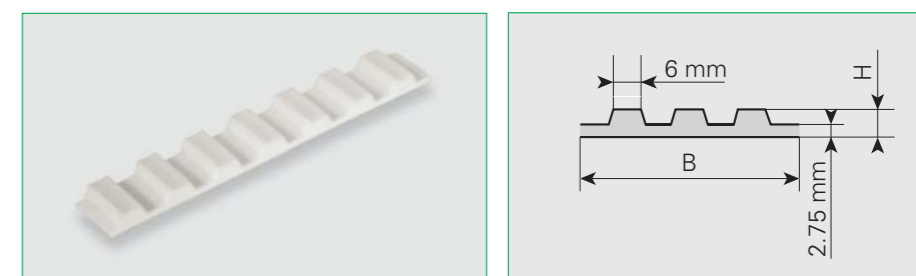

Code	Former code	Material	Color	B [mm]	H [mm]	Weight [kg/m]	Hardness [ShA]	Min. pulley diameters (longitudinal, running side) [mm]	Food compliance	Packaging unit	Total length [m]
PUG 15x5XW 08	-	TPU	White	15	5	0,15	85	40	EU/FDA	coil	100
PUG 25x5XW 08	-	TPU	White	25	5	0,171	85	40	EU/FDA	coil	100
PUG 250/6XW 08	-	TPU	White	250	6	1,052	85	40	EU/FDA	coil	100

Special PVC tracking guides



Code	Former code	Material	Color	B [mm]	H [mm]	Weight [kg/m]	Hardness [ShA]	Min. pulley diameters (longitudinal, running side) [mm]	Food compliance	Packaging unit	Total length [m]
Flat profile 20x3/LG	-	PVC	anthracite	20	3	0,051	65	30	NO	coil	200
PRS-10X3	-	PVC	anthracite	10	3	0,034	65	30	NO	coil	50
PRS-15X3	-	PVC	anthracite	15	3	0,51	65	30	NO	coil	50
PRS-20X3	-	PVC	anthracite	20	3	0,068	65	30	NO	coil	50
PRS-30X3	-	PVC	anthracite	30	3	0,102	65	30	NO	coil	50
Flat Prs 250/3xa	-	PVC	anthracite	250	3	0,9	65	30	NO	coil	50

Narrow based flights

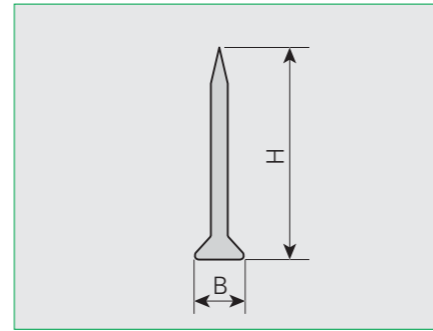
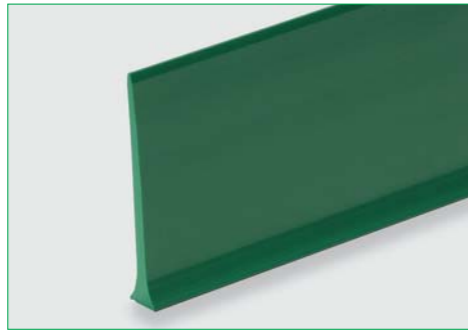

Code	Former code	Material	Color	B [mm]	H [mm]	Weight [kg/m]	Minimum pulley diameters (conveyor side) [mm]	Hardness [ShA]	Food compliance	Packaging unit	Total length [m]
PNF-20W	PNF-20XW	TPU	white	10,5	20	0,099	50	85	EU/FDA	box	144
PNF-30W	PNF-30XW	TPU	white	10,5	30	0,144	50	85	EU/FDA	box	100
PNF-40W	PNF-40XW	TPU	white	10,5	40	0,17	50	85	EU/FDA	box	60
PNF-60W	PNF-60XW	TPU	white	10,5	60	0,26	50	86	EU/FDA	box	43
PNF-20C	PNF-20XC	TPU	cobalt blue	10,5	20	0,099	50	85	EU/FDA	box	144
PNF-40C	PNF-40XC	TPU	cobalt blue	10,5	40	0,17	50	85	EU/FDA	box	60
PNF-60C	PNF-60XC	TPU	cobalt blue	10,5	60	0,26	50	85	EU/FDA	box	43
PNF-80C	PNF-80XC	TPU	cobalt blue	10,5	80	0,34	50	85	EU/FDA	box	36
PNF-20G	PNF-20/green	TPU	green	10,5	20	0,099	50	85	EU/FDA	box	144
PNF-30G	PNF-30/green	TPU	green	10,5	30	0,144	50	85	EU/FDA	box	100
PNF-40G	PNF-40/green	TPU	green	10,5	40	0,17	50	85	EU/FDA	box	60
PNF-60G	PNF-60/green	TPU	green	10,5	60	0,26	50	85	EU/FDA	box	43
PNF-30D	PNH-20	TPU	dark green	10,5	20	0,099	50	85	NO	box	144
PNF-30D	PNH-30	TPU	dark green	10,5	30	0,144	50	85	NO	box	100
PNF-40D	PNH-40	TPU	dark green	10,5	40	0,17	50	85	NO	box	60
PNF-60D	PNH-60	TPU	dark green	10,5	60	0,26	50	85	NO	box	43
PNF-80D	PNH-80	TPU	dark green	10,5	80	0,34	50	85	NO	box	36

Narrow based "bent" flights

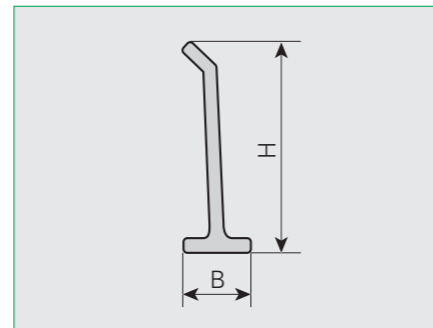
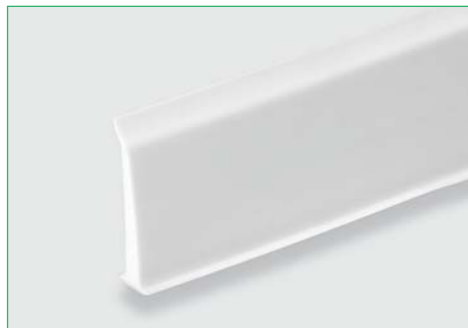

Code	Former code	Material	Color	B [mm]	H [mm]	Weight [kg/m]	Minimum pulley diameters (conveyor side) [mm]	Hardness [ShA]	Food compliance	Packaging unit	Total length [m]
PBF-20W	PbF-20xw	TPU	white	12	20	0,11	50	85	NO	box	120
PBF-30W	PbF-30xw	TPU	white	12	30	0,154	50	85	NO	box	84
PBF-40W	PbF-40xw	TPU	white	12	40	0,194	50	85	NO	box	60
PBF-50W	PbF-50xw	TPU	white	12	50	0,25	50	85	NO	box	48
PBT-20D	Pbh-20xd	TPU	dark green	12	20	0,11	50	85	EU/FDA	box	120
PBT-30D	Pbh-30xd	TPU	dark green	12	30	0,154	50	85	EU/FDA	box	84
PBT-40D	Pbh-40xd	TPU	dark green	12	40	0,194	50	85	EU/FDA	box	60
PBT-50D	Pbh-50xd	TPU	dark green	12	50	0,25	50	85	EU/FDA	box	48

T - Shaped

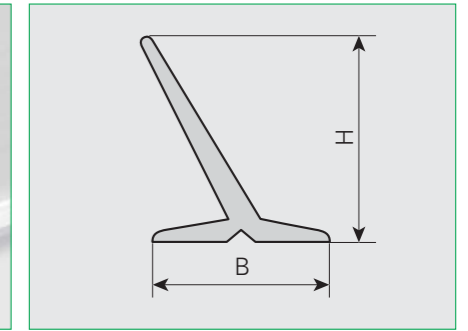
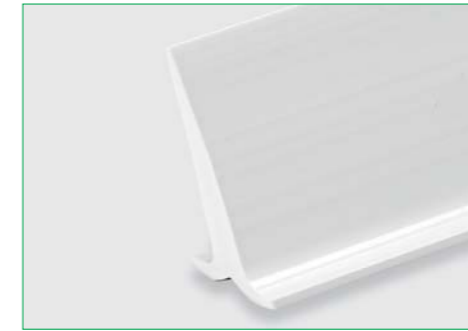

Code	Former code	Material	Color	B [mm]	H [mm]	Weight [kg/m]	Minimum pulley diameters (conveyor side) [mm]	Hardness [ShA]	Food compliance	Packaging unit	Total length [m]
PTF-20W	PTF-20	TPU	white	20	20	0,17	80	86	EU/FDA	box	156
PTF-30W	PTF-30	TPU	white	30	30	0,37	90	86	EU/FDA	box	72
PTF-40W	PTF-40	TPU	white	30	40	0,48	110	86	EU/FDA	box	60
PTF-50W	PTF-50	TPU	white	35	50	0,75	140	86	EU/FDA	box	36
PTF-70W	PTF-70	TPU	white	40	70	0,99	170	86	EU/FDA	box	24
PTF-20G	PTF-20/green	TPU	green	20	20	0,17	80	86	EU/FDA	box	156
PTF-30G	PTF-30/green	TPU	green	30	30	0,37	90	86	EU/FDA	box	72
PTF-40G	PTF-40/green	TPU	green	30	40	0,48	110	86	EU/FDA	box	60
PTF-50G	PTF-50/green	TPU	green	35	50	0,75	140	86	EU/FDA	box	36
PTF-70G	PTF-70/green	TPU	green	40	70	0,99	170	86	EU/FDA	box	24
PTF-70T	PTF-70/coloreless	TPU	transparent	40	70	0,99	170	86	EU/FDA	box	24
PTR-20W	PTV-20XW 09	PVC-FOOD	white	20	20	0,17	90	65	EU/FDA	box	156
PTR-30W	PTV-30XW 09	PVC-FOOD	white	30	30	0,37	100	65	EU/FDA	box	72
PTR-40W	PTV-40XW 09	PVC-FOOD	white	30	40	0,48	100	65	EU/FDA	box	60
PTR-50W	PTV-50XW 09	PVC-FOOD	white	35	50	0,75	120	65	EU/FDA	box	36
PTR-70W	PTV-70XW 09	PVC-FOOD	white	40	70	0,99	150	65	EU/FDA	box	24
PTR-30C	PTV-30XC 09	PVC-FOOD	cobalt blue	30	30	0,37	100	65	EU/FDA	box	72
PTR-50C	PTV-50XC 09	PVC-FOOD	anthracite	35	50	0,75	120	65	EU/FDA	box	36
PTR-70C	PTV-70XC 09	PVC-FOOD	cobalt blue	40	70	0,99	150	65	EU/FDA	box	24
PTS-20A	PTS-20	PVC	anthracite	20	20	0,17	90	65	NO	box	156
PTS-30A	PTS-30	PVC	anthracite	30	30	0,37	100	65	NO	box	72
PTS-40A	PTS-40	PVC	anthracite	30	40	0,48	100	65	NO	box	60
PTS-50A	PTS-50	PVC	anthracite	35	50	0,75	120	65	NO	box	36
PTS-70A	PTS-70	PVC	anthracite	40	70	0,99	150	65	NO	box	24
PTS-20D	PTS-20/dg	PVC	dark green	20	20	0,17	90	65	NO	box	156
PTS-30D	PTS-30/dg	PVC	dark green	30	30	0,37	100	65	NO	box	72
PTS-40D	PTS-40/dg	PVC	dark green	30	40	0,48	100	65	NO	box	60
PTS-50D	PTS-50/dg	PVC	dark green	35	50	0,75	120	65	NO	box	36
PTS-70D	PTS-70/dg	PVC	dark green	40	70	0,99	150	65	NO	box	24

Rectangular and square profiles



Code	Former code	Material	Color	B [mm]	H [mm]	Weight [kg/m]	Minimum pulley diameters (transversal, conveyor side) [mm]	Minimum pulley diameters (longitudinal, running side) [mm]	Hardness [ShA]	Food compliance	Packaging unit	Total length [m]
PQF-4 soft	PQF-4 PUR soft	TPU soft	transparent	8	4	0,04	30	40	60	NO	coil	200
PQF-4W	PQF-4	TPU	white	8	4	0,04	30	30	86	EU/FDA	coil	200
PQF-8W	PQF-8	TPU	white	8	8	0,08	50	110	86	EU/FDA	coil/box	100/300
PQF-12W	PQF-12	TPU	white	12	12	0,12	70	140	86	EU/FDA	coil/box	50/150
PQF-16W	PQF-16	TPU	white	12	16	0,17	80	160	86	EU/FDA	coil/box	50/150
PQF-12C	PQF-12XC	TPU	cobalt blue	12	12	0,12	70	140	86	EU/FDA	coil/box	50/150
PQF-8G	PQF-8/green	TPU	green	8	8	0,08	50	110	86	EU/FDA	coil/box	100/300
PQF-12G	PQF-12/green	TPU	green	12	12	0,12	70	140	86	EU/FDA	coil/box	50/150
PQF-16G	PQF-16/green	TPU	green	12	16	0,17	80	160	86	EU/FDA	coil/box	50/150
PQR-8W	PQV-8XW 09	PVC-FOOD	white	8	8	0,08	40	80	65	EU/FDA	coil/box	100/300
PQR-12W	PQV-12XW 09	PVC-FOOD	white	12	12	0,12	60	130	65	EU/FDA	coil/box	50/150
PQR-16W	PQV-16XW 09	PVC-FOOD	white	12	16	0,17	80	150	65	EU/FDA	coil/box	50/150
PQR-8C	PQV-8XC 09	PVC-FOOD	cobalt blue	8	8	0,08	40	80	65	EU/FDA	coil/box	100/300
PQR-12C	PQV-12XC 09	PVC-FOOD	cobalt blue	12	12	0,12	60	130	65	EU/FDA	coil/box	50/150
PQS-4A	PQS-4	PVC	anthracite	8	4	0,04	30	40	65	NO	coil	200
PQS-8D	PQS-8	PVC	anthracite	8	8	0,08	50	80	65	NO	coil/box	100/300
PQS-12A	PQS-12	PVC	anthracite	12	12	0,12	70	130	65	NO	coil/box	50/150
PQS-16A	PQS-16	PVC	anthracite	12	16	0,17	80	150	65	NO	coil/box	50/150
PQS-8A	PQS-8/dg	PVC	dark green	8	8	0,08	50	80	65	NO	coil/box	100/300
PQS-12D	PQS-12/dg	PVC	dark green	12	12	0,12	70	130	65	NO	coil/box	50/150
PQS-16D	PQS-16/dg	PVC	dark green	12	16	0,17	80	150	65	NO	coil/box	50/150
PQS-80x8 DG	PQS-80x8 DG	PVC	dark green	80	8	0,75	40	-	65	NO	box	36

Rectangular and square profiles can be used as tracking guides and sidewalls too.



Habibord corrugated sidewall profiles can be used in a wide range of applications to contain bulk goods on the sides of conveyor belts.

Preformed flat profiles can be cut down in height; the excellent flexibility of the polyurethane allows to keep small pulley diameters.

Suggested minimum pulley diameters are:

- Habibord 30mm → Ø 60mm
- Habibord 40mm → Ø 70mm
- Habibord 50mm → Ø 80mm
- Habibord 60mm → Ø 100mm

Preformed flat profiles for Habibord*

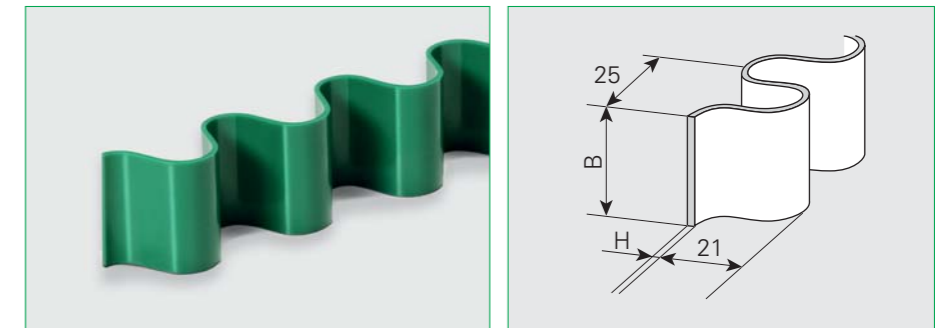

Code	Former code	Material	Color	B [mm]	H [mm]	Weight [kg/m]	Hardness [ShA]	Food compliance	Packaging unit	Total length [m]
HB-130/1.35F-W	Hb-130/1.35-tpu-xw	TPU	white	130	1,35	0,22	85	EU/FDA	box	40
HB-130/1.35F-G	Hb-130/1.35-tpu-g	TPU	green	130	1,35	0,22	85	EU/FDA	box	40
HB-130/1.35F-C	Hb-130/1,35-tpu-xc	TPU	cobalt blue	130	1,35	0,22	85	EU/FDA	box	40
HB-130/1.35T-D	Hb-130/1.35-tpu-dg	TPU	dark green	130	1,35	0,22	85	NO	box	40

* Different supply policies are applied in different countries. Please check with your local Habasit partner.

Edge sealing profile applications ensure a completely sealed, hygienic conveyor belts especially in the Food Industry. In this way no contamination of oil, fats, product particles or moisture can penetrate into the belt.

Edge sealing profiles



Code	Former code	Material	Color	B [mm]	H [mm]	Weight [kg/m]	Hardness [ShA]	Min. pulley diameters (longitudinal, conveyor side) [mm]	Min. pulley diameters (longitudinal, running side) [mm]	Food compliance	Packaging unit	Total length [m]
ARF-14/6W	ARF-14/6XW	TPU	White	14	6	0,10	85	-	-	EU/FDA	coil	100
ARR-14/6W	ARV-14/6XW 09	PVC-FOOD	White	14	6	0,10	65	-	-	EU/FDA	coil	100
ARF-14/6C	ARF-14/6XC	TPU	Cobalt blue	14	6	0,10	85	-	-	EU/FDA	coil	100
ARR-14/6C	ARV-14/6XC 09	PVC-FOOD	Cobalt blue	14	6	0,10	65	-	-	EU/FDA	coil	100
ARF-14/6G	ARF-14/6XG	TPU	green	14	6	0,10	85	-	-	EU/FDA	coil	100
ARF-14/6T	ARF-14/6XT	TPU	transparent	14	6	0,10	85	-	-	EU/FDA	coil	100
ARS-14/6A	ARS-14/6XA	PVC	anthracite	14	6	0,10	65	-	-	NO	coil	100
ARS-14/6B	ARV-14/6XB	PVC	black	14	6	0,10	65	-	-	NO	coil	100

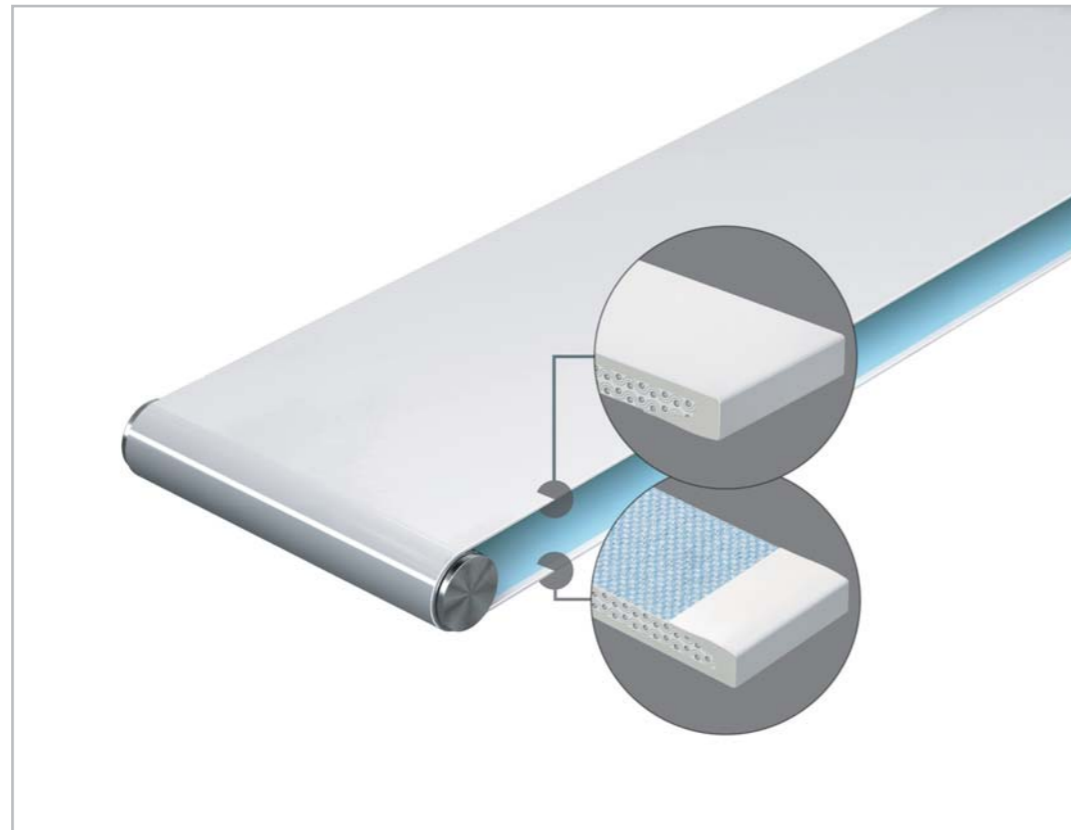

CEU profiles can be applied on belts as guiding system in power turn applications

CEU 25

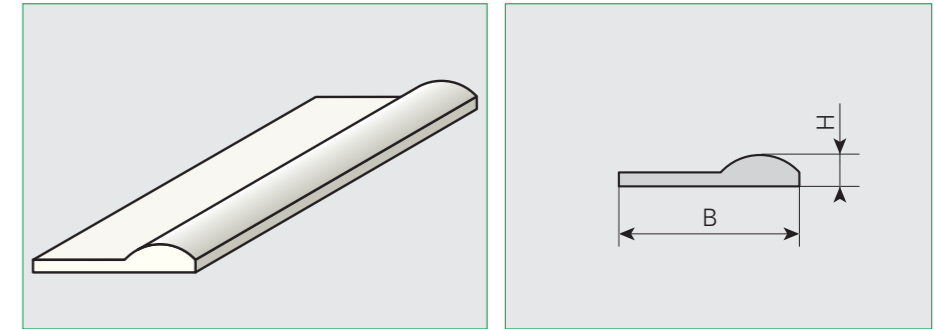

CEU 30

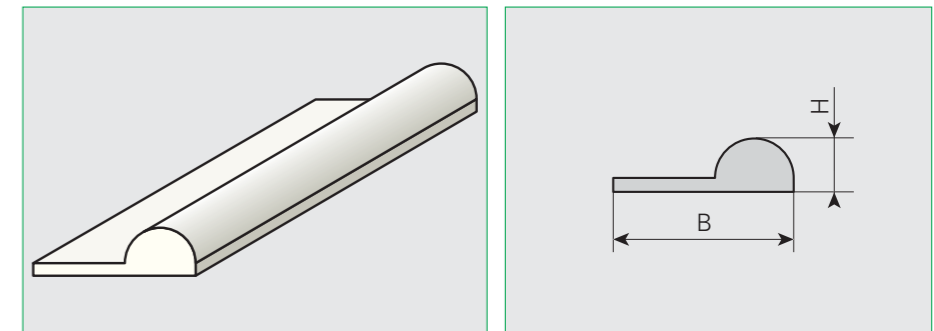

CEU 40

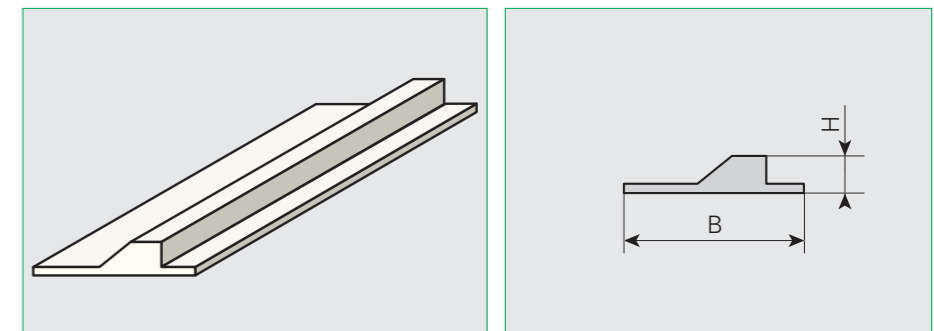

Code	Former code	Material	Color	B [mm]	H [mm]	Weight [kg/m]	Hardness [ShA]	Min. pulley diameters (longitudinal, conveyor side) [mm]	Min. pulley diameters (longitudinal, running side) [mm]	Food compliance	Packaging unit	Total length [m]
CEU 25	-	TPU	Natural	25	5	0,09	85	-	-	NO	coil	100
CEU 30	-	TPU	Natural	30	7,5	0,13	85	-	-	NO	coil	100
CEU 40	-	TPU	Natural	40	7	0,13	85	-	-	NO	coil	100

Habipur

Habipur is the range of V-shaped polyurethane profiles, mostly used as conveyor belts in the Ceramic Industry.

Available in different shapes and dimensions, with and without an inside PET yarn reinforcement.

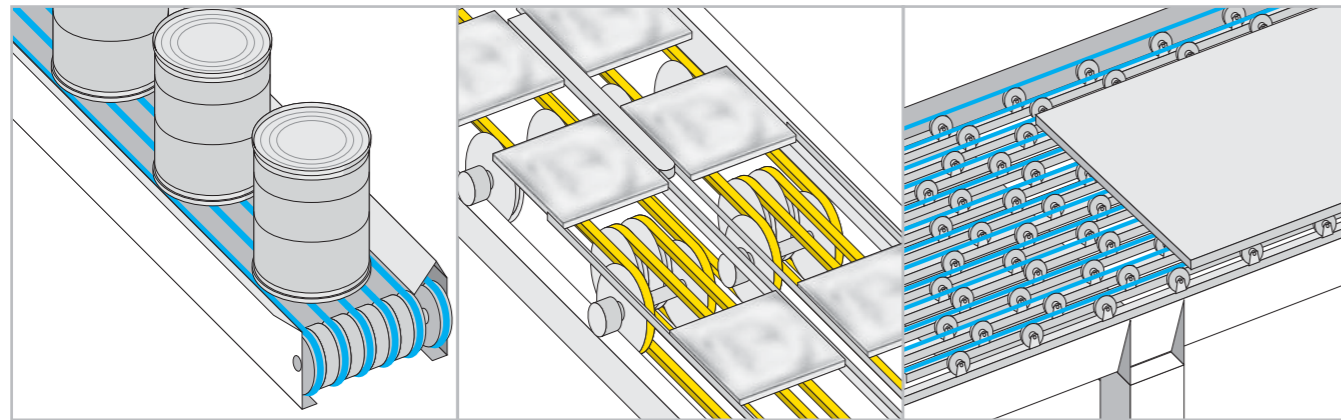

Habipur

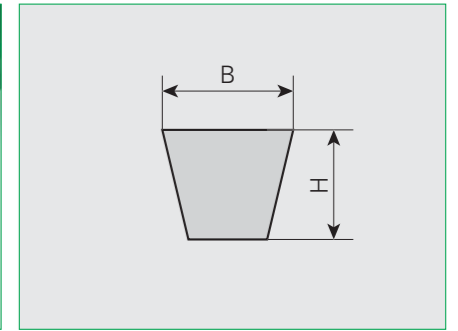

Code	Material	Color	B [mm]	H [mm]	Weight [kg/m]	Minimum pulley diameters [mm]	Nominal peripheral force [N]	Hardness [ShA]	Food Compliance	Packaging unit	Total length [m]
HABIPUR T-10	TPU	Green	10	6	0,06	55	40	85	NO	coil	200
HABIPUR T-13	TPU	Green	13	8	0,1	65	70	85	NO	coil	100
HABIPUR T-17	TPU	Green	17	11	0,17	80	130	85	NO	coil	50
HABIPUR T-17/RED	TPU	Red	17	11	0,17	80	130	85	NO	coil	50
HABIPUR T-22	TPU	Green	22	14	0,28	130	240	85	NO	coil	50

Raised Habipur

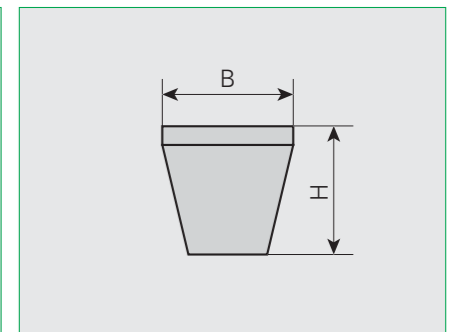
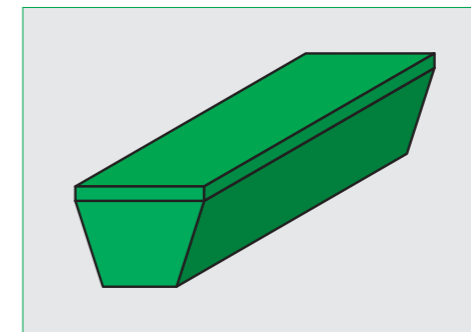

Code	Material	Color	B [mm]	H [mm]	Weight [kg/m]	Minimum pulley diameters [mm]	Nominal peripheral force [N]	Hardness [ShA]	Food Compliance	Packaging unit	Total length [m]
HABIPUR T-10/R GREEN	TPU	Green	10	7,5	0,09	70	60	85	NO	coil	100
HABIPUR T-13/R GREEN	TPU	Green	13	10	0,12	80	70	85	NO	coil	100
HABIPUR T-17/R GREEN	TPU	Green	17	14	0,22	90	150	85	NO	coil	50

Crested Habipur

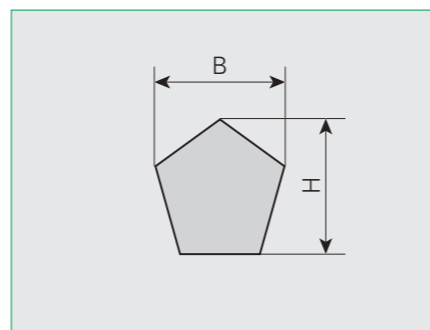
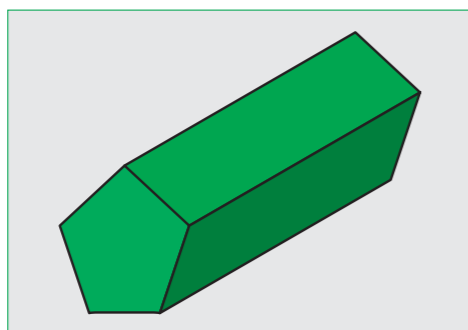

Code	Material	Color	B [mm]	H [mm]	Weight [kg/m]	Minimum pulley diameters [mm]	Nominal peripheral force [N]	Hardness [ShA]	Food Compliance	Packaging unit	Total length [m]
HABIPUR T-17/C GREEN	TPU	Green	17	20	0,28	175	340	85	NO	coil	100
HABIPUR T-22/C GREEN	TPU	Green	22	28	0,45	225	410	85	NO	coil	100

Habipur with honeycomb rubber cover

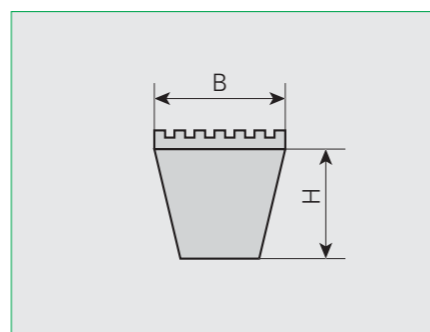
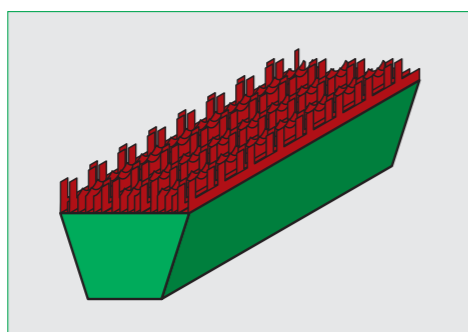

Code	Material	Color	B [mm]	H [mm]	Weight [kg/m]	Minimum pulley diameters [mm]	Nominal peripheral force [N]	Hardness [ShA]	Food Compliance	Packaging unit	Total length [m]
HABIPUR T-10/GRIP	TPU	Green	10	6	0,09	65	40	85	NO	coil	50
HABIPUR T-13/GRIP	TPU	Green	13	8	0,14	75	50	85	NO	coil	50
HABIPUR T-17/GRIP	TPU	Green	17	11	0,24	85	120	85	NO	coil	50
HABIPUR T-22/GRIP	TPU	Green	22	14	0,36	130	160	85	NO	coil	50

Reinforced Habipur

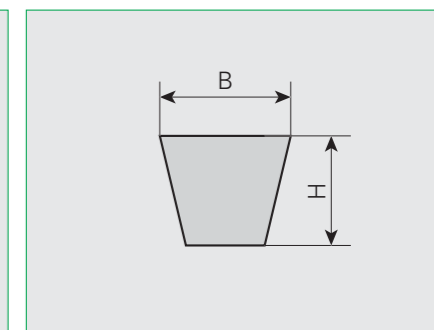
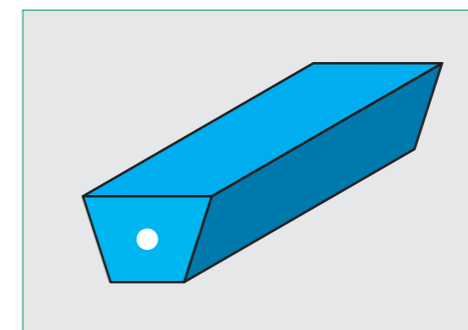

Code	Material	Color	B [mm]	H [mm]	Weight [kg/m]	Minimum pulley diameters [mm]	Nominal peripheral force [N]	Hardness [ShA]	Food Compliance	Packaging unit	Total length [m]
HABIPUR R85 B 13	TPU	Blue	13	8	0,1	75	230	85	NO	coil	100
HABIPUR R85 B 17	TPU	Blue	17	11	0,18	100	320	85	NO	coil	50
HABIPUR R85 R 17/RED	TPU	Red	17	11	0,18	100	320	85	NO	coil	50
HABIPUR R85 B 22	TPU	Blue	22	14	0,27	130	410	85	NO	coil	50

Reinforced Habipur with honeycomb rubber cover

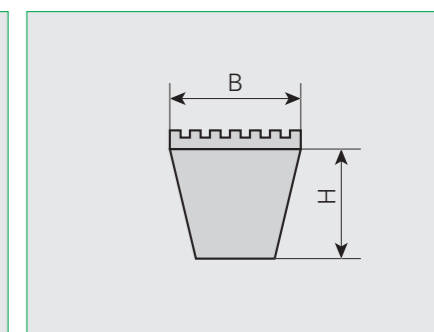
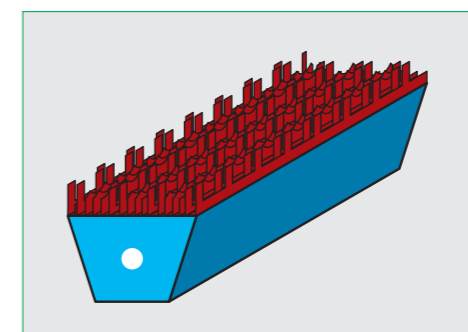

Code	Material	Color	B [mm]	H [mm]	Weight [kg/m]	Minimum pulley diameters [mm]	Nominal peripheral force [N]	Hardness [ShA]	Food Compliance	Packaging unit	Total length [m]
HABIPUR R85 B13/GRIP	TPU	Blue	13	8	0,15	60	180	85	NO	coil	50
HABIPUR R85 B17/GRIP	TPU	Blue	17	11	0,24	80	230	85	NO	coil	50

Reinforced Habipur with crested profiles

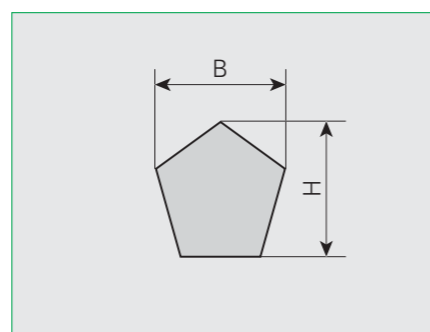
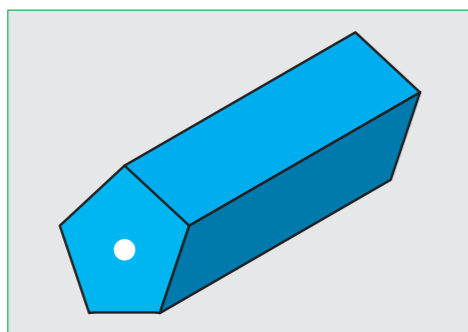

Code	Material	Color	B [mm]	H [mm]	Weight [kg/m]	Minimum pulley diameters [mm]	Nominal peripheral force [N]	Hardness [ShA]	Food Compliance	Packaging unit	Total length [m]
HABIPUR RC85 B 17	TPU	Blue	17	20	0,28	160	320	85	NO	coil	50
HABIPUR RC85 B 22	TPU	Blue	22	24	0,42	180	450	85	NO	coil	50
HABIPUR RC75 R 22RED	TPU	Red	22	14	0,42	180	450	85	NO	coil	50

Reinforced Habipur R75G

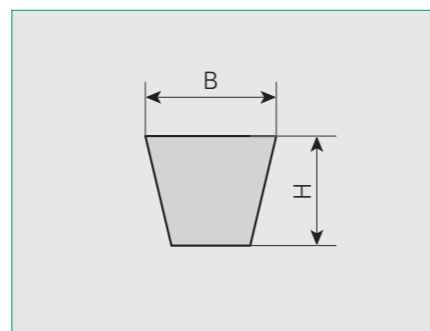
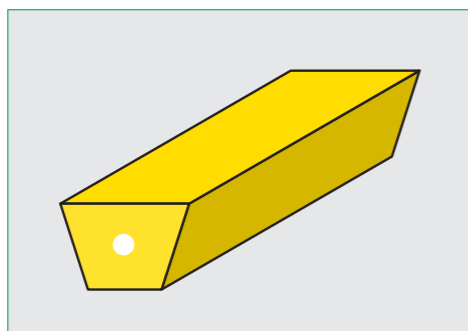

Code	Material	Color	B [mm]	H [mm]	Weight [kg/m]	Minimum pulley diameters [mm]	Nominal peripheral force [N]	Hardness [ShA]	Food Compliance	Packaging unit	Total length [m]
HABIPUR R75 G 13	TPU	Yellow	13	8	0,1	45	70	75	NO	coil	100
HABIPUR R75 G 17	TPU	Yellow	17	11	0,19	70	270	75	NO	coil	50
HABIPUR R75 G 22	TPU	Yellow	22	14	0,28	95	460	75	NO	coil	50
HABIPUR R75 R 22/RED	TPU	Red	22	24	0,28	95	460	75	NO	coil	50

Habipur for diverters

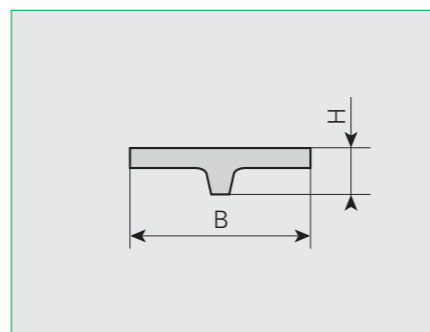

Code	Material	Color	B [mm]	H [mm]	Weight [kg/m]	Minimum pulley diameters [mm]	Nominal peripheral force [N]	Hardness [ShA]	Food Compliance	Packaging unit	Total length [m]
PUR 25X5/A WHITE	TPU	White	25	5	0,075	50	-	85	NO	coil	50
PUR 25X5/A GREEN	TPU	Green	25	5	0,075	50	-	85	NO	coil	50
PUR 12X5/A WHITE	TPU	White	25	5	0,075	50	-	85	NO	coil	200

Habicord is the range of extruded polyurethane round belts. Thanks to their high flexibility and elastic properties, Habicord are suitable for small pulley diameters. Round belts are mostly used in textile, packaging, paper, ceramics and wood industries for power transmission, live roller drives and linear conveyors.

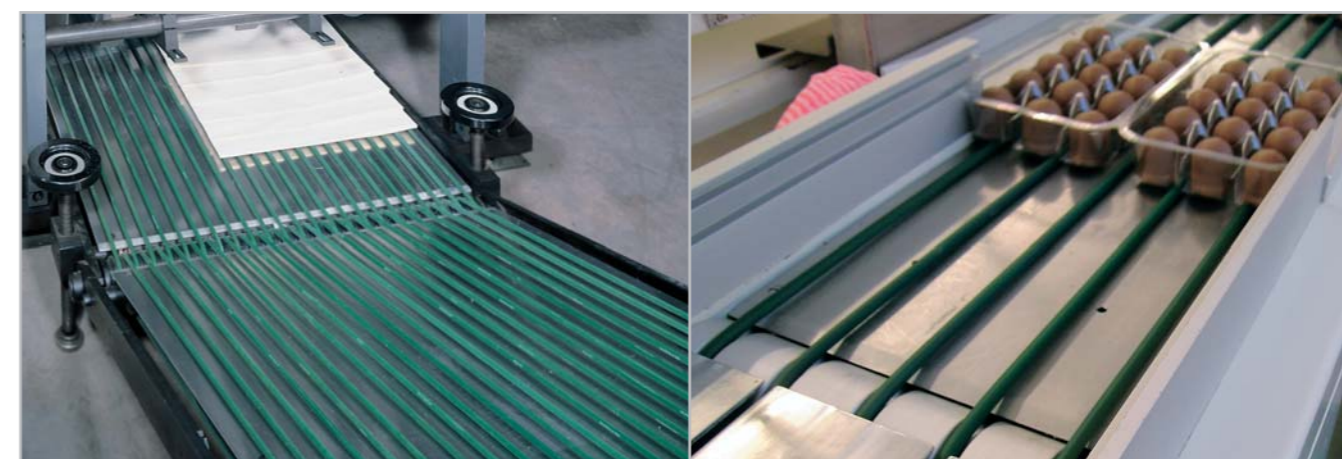

Regular Habicord



Code	Material	Color	Diameter [mm]	Weight [g/m]	Minimum pulley diameters [mm]	K8% [N]	Nominal peripheral force [N]	Hardness [ShA]	Coil length [m]	Food compliance
HABICORD D2	TPU	Green	2	8	30	17	12	85	300	NO
HABICORD D3	TPU	Green	3	17	40	21	15	85	250	NO
HABICORD D4	TPU	Green	4	25	50	35	25	85	250	NO
HABICORD D5	TPU	Green	5	35	60	49	35	85	250	NO
HABICORD D6	TPU	Green	6	48	70	70	50	85	200	NO
HABICORD D8	TPU	Green	8	58	80	80	60	85	200	NO
HABICORD D10	TPU	Green	10	96	100	146	100	85	100	NO
HABICORD D12	TPU	Green	12	131	120	200	140	85	100	NO
HABICORD D15	TPU	Green	15	208	150	250	175	85	50	NO
HABICORD D20/7	TPU	Green	20/7	290	200	350	240	85	50	NO

Smooth Habicord

Code	Material	Color	Diameter [mm]	Weight [g/m]	Minimum pulley diameters [mm]	K8% [N]	Nominal peripheral force [N]	Hardness [ShA]	Coil length [m]	Food compliance
HABICORD D6,3-SMOOTH	TPU	Green	6,3	37	60	105	81	85	250	NO
HABICORD D8-SMOOTH	TPU	Green	8	60	80	150	115	85	200	NO
HABICORD D10-SMOOTH	TPU	Green	10	94	100	225	175	85	100	NO
HABICORD D12-SMOOTH	TPU	Green	12	133	120	330	255	85	100	NO

Rough Habicord

Code	Material	Color	Diameter [mm]	Weight [g/m]	Minimum pulley diameters [mm]	K8% [N]	Nominal peripheral force [N]	Hardness [ShA]	Coil length [m]	Food compliance
HABICORD D2-ROUGH	TPU	Green	2	4	20	11	7	85	500	NO
HABICORD D3-ROUGH	TPU	Green	3	9	30	17	10	85	300	NO
HABICORD D4-ROUGH	TPU	Green	4	15	40	30	20	85	250	NO
HABICORD D5-ROUGH	TPU	Green	5	24	50	48	30	85	250	NO
HABICORD D6-ROUGH	TPU	Green	6	34	60	73	45	85	250	NO
HABICORD D8-ROUGH	TPU	Green	8	57	80	125	75	85	200	NO
HABICORD D12-ROUGH	TPU	Green	12	137	120	150	123	85	100	NO
HABICORD D15-ROUGH	TPU	Green	15	200	150	250	175	85	50	NO

Extraelastic



Code	Material	Color	Diameter [mm]	Weight [g/m]	Minimum pulley diameters [mm]	K8% [N]	Nominal peripheral force [N]	Hardness [ShA]	Coil length [m]	Food compliance
EXTRAEL D5	TPU	Green	5	60	50	30	20	75	250	NO
EXTRAEL D6	TPU	Green	6	94	60	48	30	75	250	NO

Polywhite

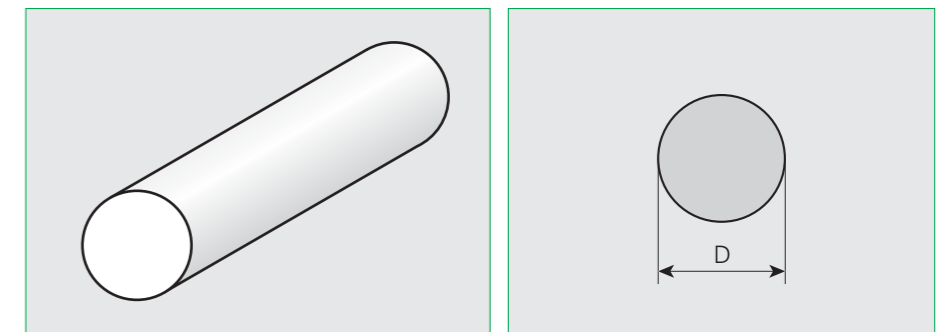

Code	Material	Color	Diameter [mm]	Weight [g/m]	Minimum pulley diameters [mm]	K8% [N]	Nominal peripheral force [N]	Hardness [ShA]	Coil length [m]	Food compliance
POLYWHITE D3	TPU	White	3	10	30	19	15	85	300	NO
POLYWHITE D4	TPU	White	4	16	40	30	20	85	250	NO
POLYWHITE D5	TPU	White	5	25	50	50	35	85	250	NO
POLYWHITE D6	TPU	White	6	36	60	75	50	85	250	NO
POLYWHITE D7	TPU	White	7	46	70	96	65	85	200	NO
POLYWHITE D8	TPU	White	8	60	80	139	100	85	200	NO
POLYWHITE D10	TPU	White	10	94	100	239	160	85	100	NO
POLYWHITE D12	TPU	White	12	97	120	295	200	85	100	NO
POLYWHITE D15	TPU	White	15	208	150	550	380	85	50	NO

Reinforced Habicord have an inner PET yarn reinforcement.

Reinforced Habicord

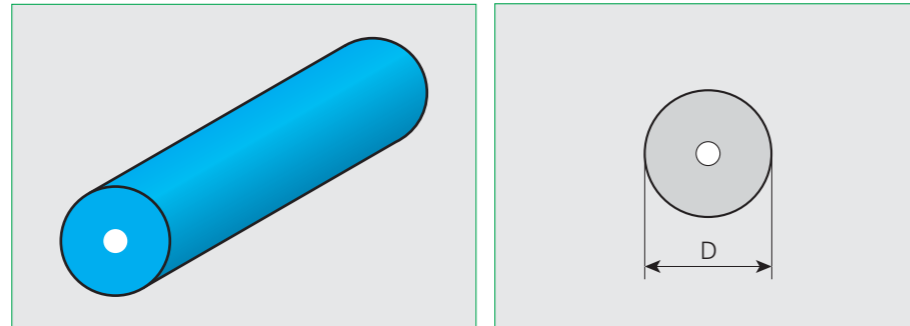

Code	Material	Color	Diameter [mm]	Weight [g/m]	Minimum pulley diameters [mm]	K1% [N]	Nominal peripheral force [N]	Hardness [ShA]	Coil length [m]	Food compliance
HABICORD RB 4	TPU	Blue	4	17	40	74	145	85	250	NO
HABICORD RB 6	TPU	Blue	6	34	60	105	170	85	250	NO
HABICORD RB 10	TPU	Blue	10	95	100	150	200	85	100	NO
HABICORD RB 12	TPU	Blue	12	136	120	220	230	85	100	NO
HABICORD RB 12.5	TPU	Blue	12,5	145	125	285	265	85	100	NO

It is suggested to not exceed 1% of initial tension.

Habiblu thermoplastic extruded profiles are the excellent solution for the conveyance of light-weight, thin sliced food products.

Habiblu products can be used in the Bakery, Meat and Cheese processing industries.

Special features:

- Hydrolysis resistance: Habiblu provides a greater resistance compared with standard extruded profiles in conditions subject to hydrolysis
- High abrasion resistance
- Food approved (FDA and European regulations)

Habiblu range consists of extruded round belts (from 3mm to 12mm of diameter) and special profiles (i.e. PUR 25x5 Blue FDA, PUR 28x5x2D Blue FDA) that can be used for diverters or line conveyors in general.

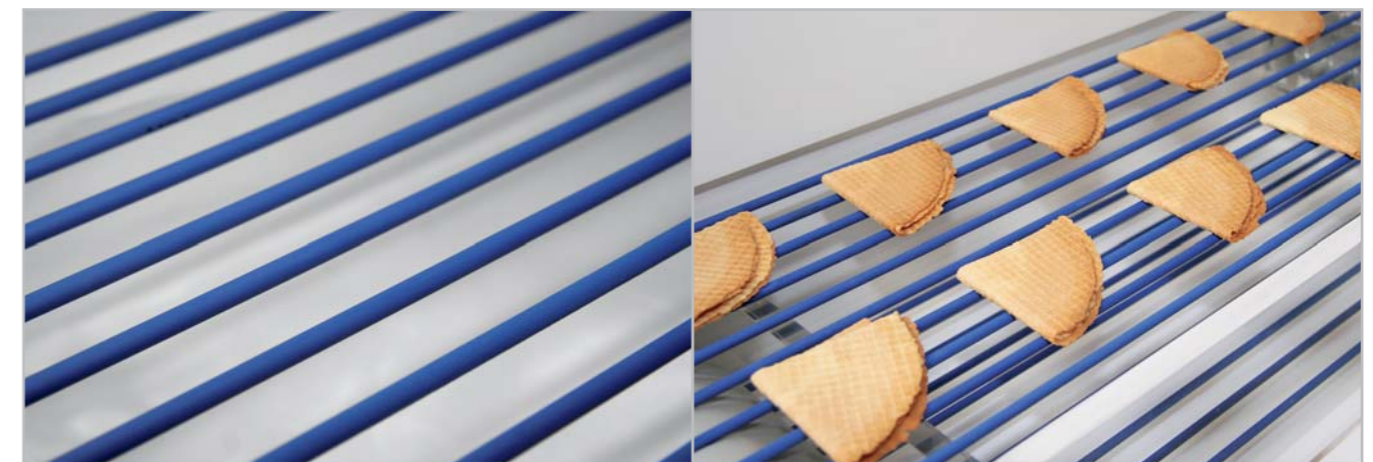
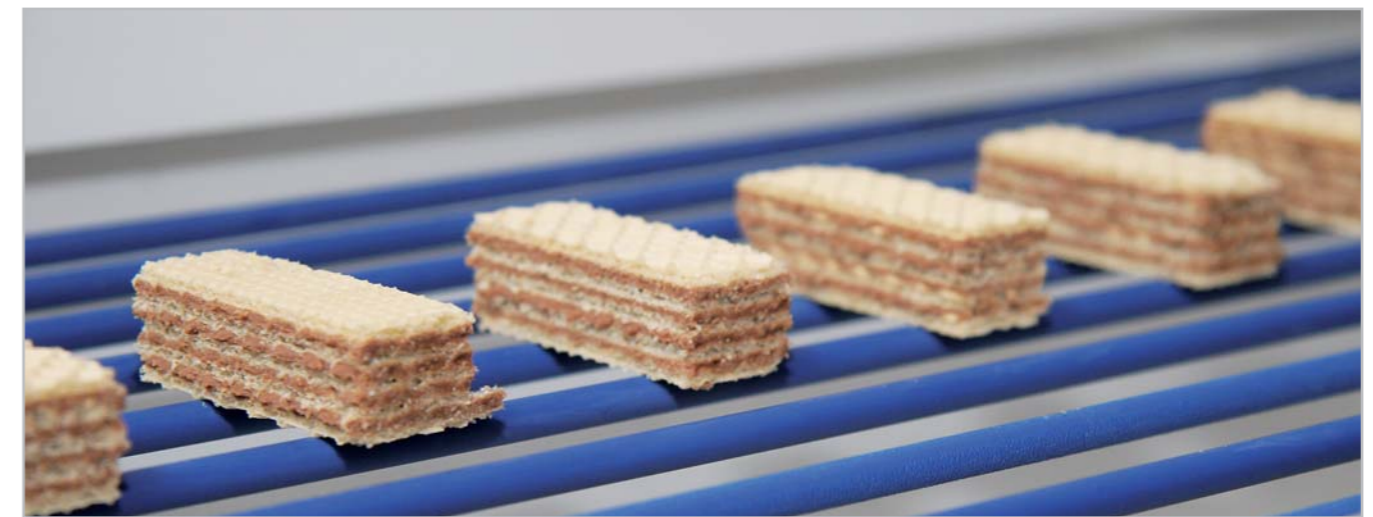

Round belts



Code	Material	Color	Diameter [mm]	Weight [kg/m]	Minimum pulley diameters [mm]	K8% * [N]	Nominal peripheral force [N]	Hardness [ShA]	Coil length [m]	Food compliance
HABIBLUE 3 FDA	Habibblue TPU	Cobalt blue	3	0,009	30	13	12	86	250	EU/FDA
HABIBLUE 4 FDA	Habibblue TPU	Cobalt blue	4	0,015	40	23	15	86	250	EU/FDA
HABIBLUE 5 FDA	Habibblue TPU	Cobalt blue	5	0,023	50	35	25	86	300	EU/FDA
HABIBLUE 6 FDA	Habibblue TPU	Cobalt blue	6	0,034	60	51	35	86	250	EU/FDA
HABIBLUE 8 FDA	Habibblue TPU	Cobalt blue	8	0,06	80	91	50	86	200	EU/FDA
HABIBLUE 10 FDA	Habibblue TPU	Cobalt blue	10	0,10	100	142	60	86	100	EU/FDA
HABIBLUE 12 FDA	Habibblue TPU	Cobalt blue	12	0,137	120	204	100	86	100	EU/FDA

V-Shaped

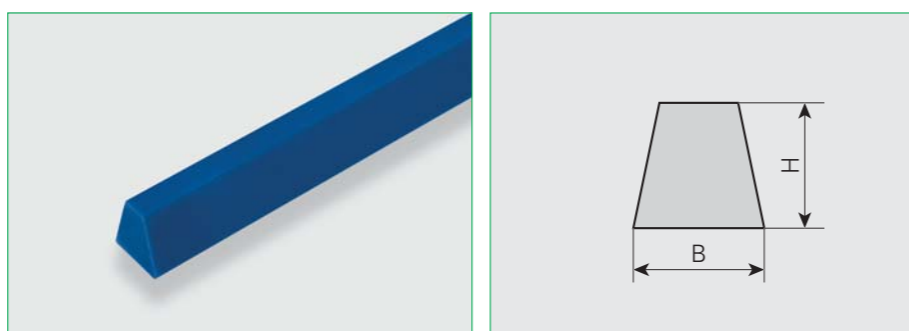

Code	Material	Color	B [mm]	H [mm]	Weight [kg/m]	Minimum pulley diameters [mm]	K8% * [N]	Hardness [ShA]	Coil length [m]	Food compliance
T-10x8 W	Habibblue TPU	White	10	8	0,062	80	140	86	200	EU/FDA
T-10x8 B	Habibblue TPU	Cobalt blue	10	8	0,062	80	140	86	200	EU/FDA

* Suggested initial tension for Habibblue range: not higher than 3%

PUR 25x5 FDA and PUR 28x5x2D special profiles are included in Habibblue range and can be used in linear conveyors and diverter applications especially in the Bakery Industry.

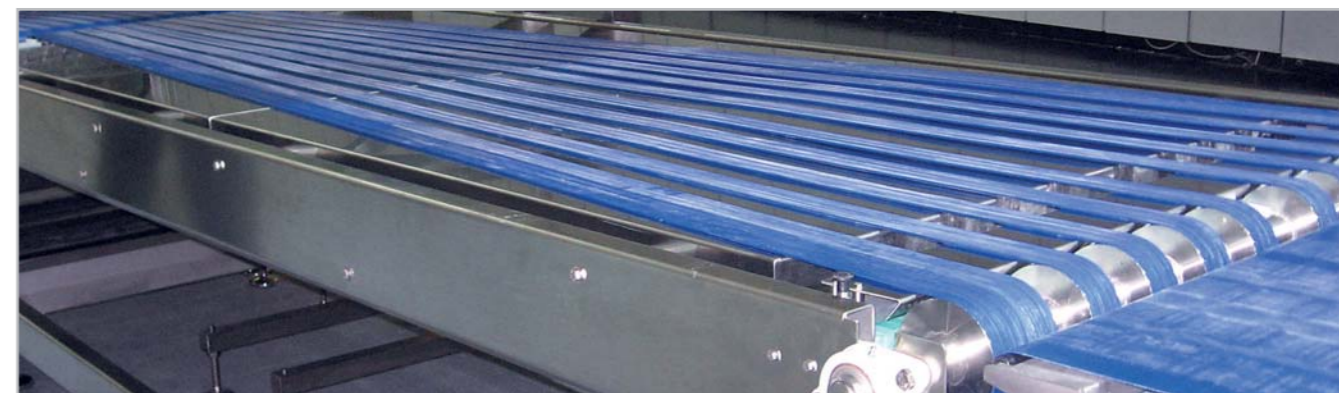

**PUR 12x5 FDA
PUR 25x5 FDA**



Code	Material	Color	B [mm]	H [mm]	Weight [kg/m]	Minimum pulley diameters [mm]	K8%* [N]	Hardness [ShA]	Coil length [m]	Food compliance
PUR 25x5 Blue FDA	Habibblue TPU	Cobalt blue	25	5	0,08	40	38	86	50	EU/FDA
PUR 25X5 White FDA	Habibblue TPU	White	25	5	0,08	40	38	86	50	EU/FDA
PUR 12x5/A White FDA	Habibblue TPU	White	12	5	0,06	40	38	86	200	EU/FDA
PUR 12x5/A Blue FDA	Habibblue TPU	Cobalt blue	12	5	0,06	40	38	86	200	EU/FDA

PUR 28x5x2D Blue FDA



Code	Material	Color	B [mm]	H [mm]	Weight [kg/m]	Minimum pulley diameters [mm]	K8%* [N]	Hardness [ShA]	Coil length [m]	Food compliance
PUR 28X5X2D BLUE FDA	Habibblue TPU	Cobalt blue	28	5	0,085	50	35	86	100	EU/FDA

* Suggested initial tension for Habibblue range: not higher than 3%

A broad selection of covers for HabaSYNC® Timing belts is available. Covers provide the friction needed to handle products so that they are correctly indexed and securely managed.

Habasit extruded TPU covers can be used in multiple applications and in the most conditions. They can provide a combination of features that include:

- Abrasion resistance
- Chemical resistance
- High or low coefficient of friction
- Food compliance
- Gentle movement
- Shock absorption

A wide range of tracking guides completes the HabaSYNC® range of accessories.

All HabaSYNC® profiles are available in standard coil dimension only.

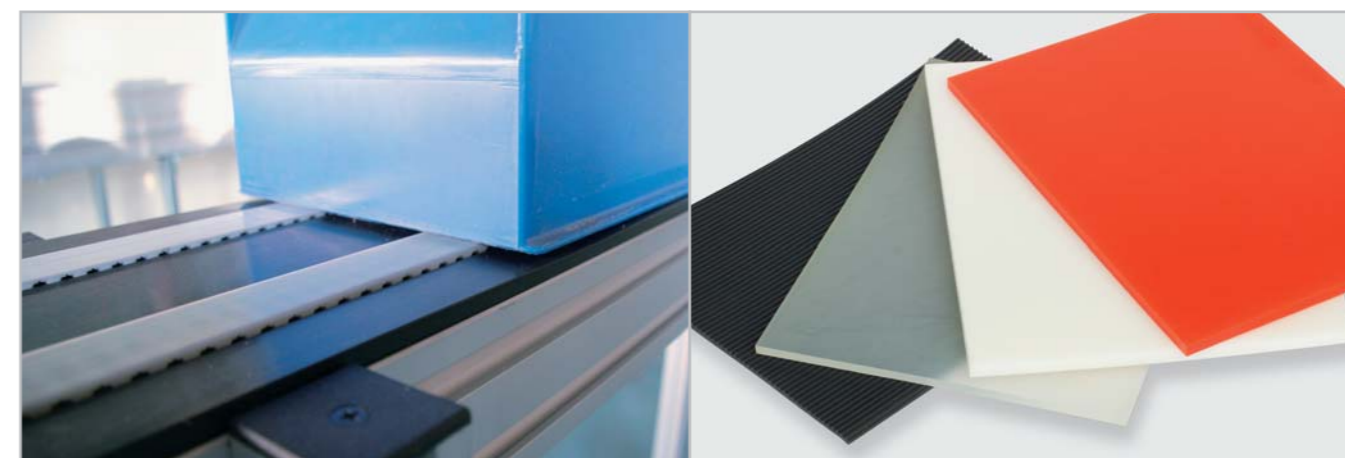

Code system for HabaSYNC® covers.

PQF-250/2.0XW85

- PQ:** flat profile
- F:** Polyurethane
- 250:** nominal width
- 2.0:** thickness
- XW:** color
- 85:** Hardness [ShA]

Flat profiles for HabaSYNC®

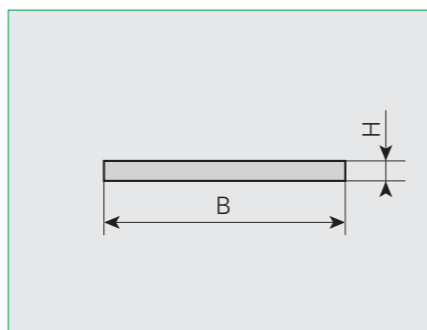
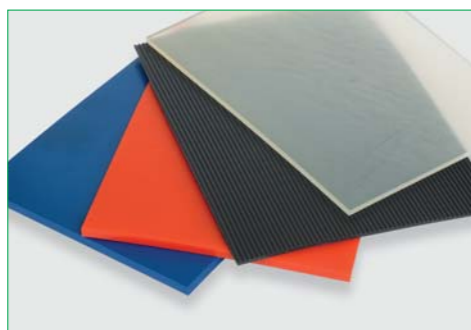

Habipur for diverters	Former code	Material	Color	B [mm]	H [mm]	Weight [kg/m]	Minimum pulley diameters [mm]	Hardness [ShA]	Food compliance	Packaging unit	Total length [m]
Flat PQF-250/2,5XB60LG	-	TPU	Black	285	2,50	2,55	-	60	NO	coil	100
Flat PQF-250/1,5XT60	-	TPU	Transparent	270	1,50	2,20	-	60	EU/FDA	coil	100
Flat PQF-250/2,0XT60	-	TPU	Transparent	270	2,00	2,48	-	60	EU/FDA	coil	100
Flat PQF-250/3,0XT60	-	TPU	Transparent	260	3,00	3,69	-	60	EU/FDA	coil	50
Flat PQF-250/4,0XT60	-	TPU	Transparent	240	4,00	5,00	-	60	EU/FDA	coil	50
Flat PQF-250/5,0XT60	-	TPU	Transparent	240	5,00	6,38	-	60	EU/FDA	coil	50
Flat PQF-250/2,0XC85	-	TPU	Cobalt blue	280	2,00	2,32	-	85	EU/FDA	coil	100
Flat PQF-250/3,0XC85	-	TPU	Cobalt blue	260	3,00	3,77	-	85	EU/FDA	coil	50
Flat PQF-250/2,0XN92	-	TPU	Natural	270	2,00	2,48	-	92	EU/FDA	coil	100
Flat PQF-250/3,0XN92	-	TPU	Natural	260	3,00	3,77	-	92	EU/FDA	coil	50
Flat PQF-250/4,0XN92	-	TPU	Natural	240	4,00	5,16	-	92	EU/FDA	coil	50
Flat PQF-250/5,0XN92	-	TPU	Natural	230	5,00	6,40	-	92	EU/FDA	coil	25
Flat PQF-250/1,35XW85	Flat Pqf-250/1,35xw	TPU	White	270	1,35	1,79	-	85	EU/FDA	coil	100
Flat PQF-250/1,35XG85	Flat Pqf-250/1,35xg	TPU	Green	270	1,35	1,79	-	85	EU/FDA	coil	100
Flat PQF-250/1,35XDG85	Flat Pqf-250/1,35xdg	TPU	Dark Green	270	1,35	1,79	-	85	NO	coil	100
Flat PQF-250/1,7XW85	Flat Pqf-250/1,7xw	TPU	White	270	1,70	1,89	-	85	EU/FDA	coil	100
Flat PQF-250/2,0XW85	Flat Pqf-250/2,0xw	TPU	White	270	2,00	2,32	-	85	EU/FDA	coil	100
Flat PQF-250/2,3XW85	Flat Pqf-250/2,3xw	TPU	White	260	2,30	2,55	-	85	EU/FDA	coil	100
Flat PQF-250/3,0XW85	Flat Pqf-250/3,0xw	TPU	White	260	3,00	3,69	-	85	EU/FDA	coil	50
Flat PQF-250/3,0XT85	Flat Pqf-250/3,0xt	TPU	Transparent	260	3,00	3,69	-	85	EU/FDA	coil	50
Flat PQF-250/4,0XW85	Flat Pqf-250/4,0xw	TPU	White	240	4,00	5,22	-	85	EU/FDA	coil	50
Flat PQF-250/5,0XW85	Flat Pqf-250/5,0xw	TPU	White	240	5,00	6,29	-	85	EU/FDA	coil	50
Flat PQF-250/2,0XR55	-	TPU	Red	270	2,00	2,30	-	55	NO	coil	100
Flat PQF-250/3,0XR56	-	TPU	Red	260	3,00	3,50	-	55	NO	coil	50

Tracking guides for HabaSYNC®

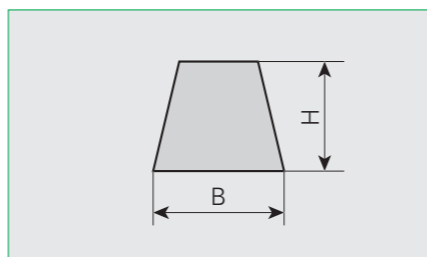

Code	Former code	Material	Color	B [mm]	H [mm]	b [mm]	Weight [kg/m]	Hardness [ShA]	Food compliance	Packaging unit	Total length [m]
PVF-6x4.0W92-SN		TPU	White	6	4		0,026	92	NO	coil	300
PVF-10x5.0W92-SN		TPU	White	10	5		0,052	92	NO	coil	200
PVF-9,7x6,1W92-SN		TPU	White	9,7	6,1		0,052	92	NO	coil	200
PVF-12,7x6,1W92-SN		TPU	White	12,7	6,1		0,065	92	NO	coil	100
PVF-13x6.5W92-SN		TPU	White	13	6,5		0,087	92	NO	coil	100

Habait Cleandrive™ is offered with a full range of thermoplastic extruded and weldable cleats, scoops and sidewalls, all designed to meet the highest standards of hygiene.

Made with the same material as the belt, Habait Cleandrive™ profiles have high chemical and hydrolysis resistance.

All Cleandrive accessories are EU and FDA food contact compliant.

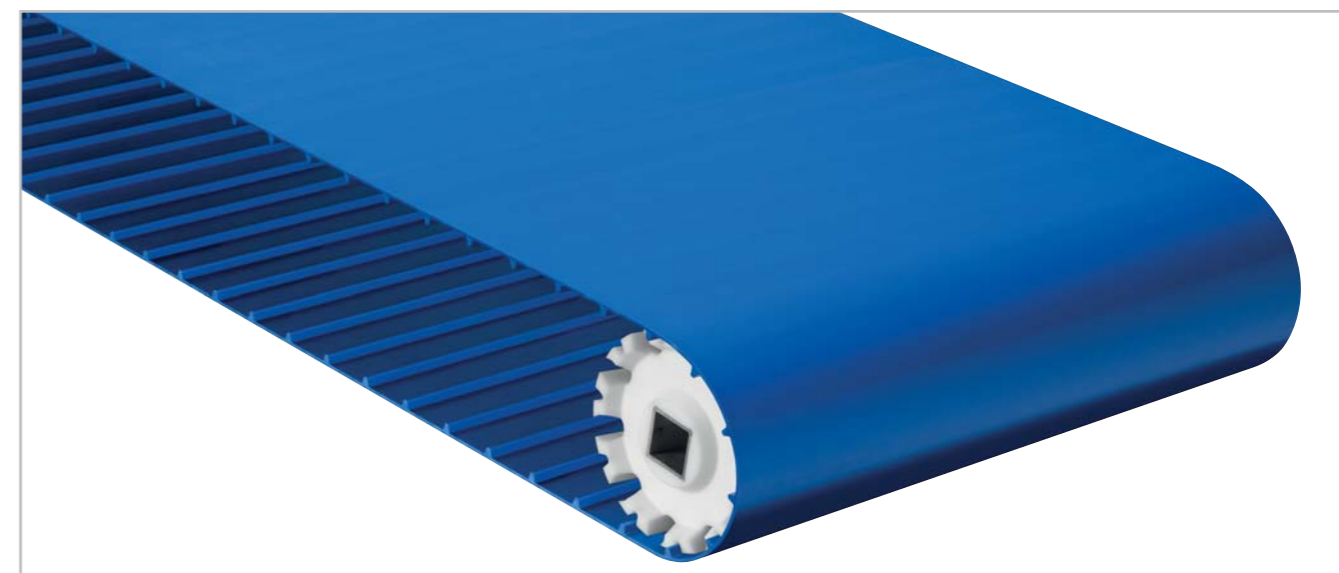

Scoop profiles



Code	Former code	Material	Color	B [mm]	H [mm]	Weight [kg/m]	Minimum pulley diameters (conveyor side) [mm]	Hardness [ShA]	Food compliance	Packaging unit	Total length [m]
PSH-100W	-	Cleandrive TPU	White	18	100	0,88	50	86	EU/FDA	box	14,4
PSH-100C	-	Cleandrive TPU	Cobalt blue	18	100	0,88	50	86	EU/FDA	box	14,4

Joining welding rod

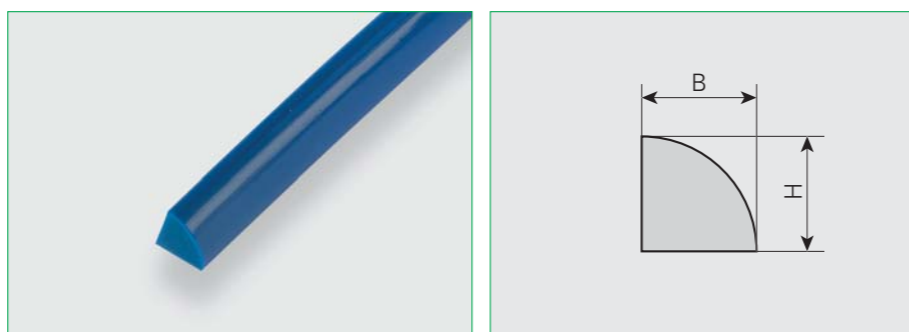

Code	Former code	Material	Color	B [mm]	H [mm]	Weight [kg/m]	Minimum pulley diameters [mm]	Hardness [ShA]	Food compliance	Packaging unit	Total length [m]
TWR-7XW	-	Cleandrive TPU	White	7	7	0,013	-	86	EU/FDA	coil	200
TWR-7WC	-	Cleandrive TPU	Cobalt blue	7	7	0,013	-	86	EU/FDA	coil	200

Flat profiles for Habasit Cleandrive™

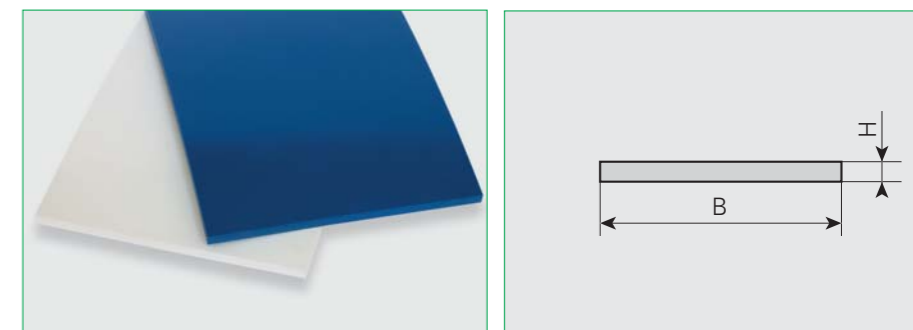

Code	Former code	Material	Color	B [mm]	H [mm]	Weight [kg/m]	Minimum pulley diameters [mm]	Hardness [ShA]	Food compliance	Packaging unit	Total length [m]
Flat 250/1.35H-W	FLAT PQF/M-250/1.35XW	Cleandrive TPU	White	270	1,35	-	-	86	EU/FDA	coil	100
Flat 250/1.35H-C	FLAT PQF/M-250/1.35XC	Cleandrive TPU	Cobalt blue	270	1,35	-	-	86	EU/FDA	coil	100
Flat 250/2,2H-C	FLAT PQF/M-250/2,2XC	Cleandrive TPU	Cobalt blue	260	2,2	-	-	86	EU/FDA	coil	100
Flat 250/5.0H-W	FLAT PQF/M-250/5.0XW	Cleandrive TPU	White	240	5,00	1,84	-	86	EU/FDA	coil	25
Flat 250/5.0H-C	FLAT PQF/M-250/5.0XC	Cleandrive TPU	Cobalt blue	240	5,00	1,84	-	86	EU/FDA	coil	25

Preformed Habibord*

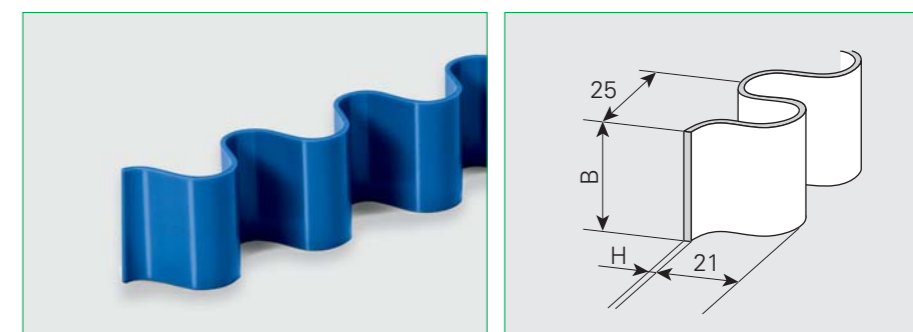

Code	Former code	Material	Color	B [mm]	H [mm]	Weight [kg/m]	Minimum pulley diameters [mm]	Hardness [ShA]	Food compliance	Packaging unit	Total length [m]
HB 130/1.35 H-W	HB 130/1,35 TPU/MXW	Cleandrive TPU	White	130	1,35	0,24	-	86	EU/FDA	box	40
HB 130/1.35 H-C	HB 130/1,35 TPU/MXC	Cleandrive TPU	Cobalt blue	130	1,35	0,24	-	86	EU/FDA	box	40

* Different supply policies are applied in different countries. Please check with your local Habasit partner.

Cleats



Code	Former code	Material	Color	B [mm]	H [mm]	Weight [kg/m]	Minimum pulley diameters (conveyor side) [mm]	Hardness [ShA]	Food compliance	Packaging unit	Total length [m]
PNH-30W	PNF/M-30XW	Cleandrive TPU	White	10,5	30	0,14	50	86	EU/FDA	box	100
PNH-60W	PNF/M-60XW	Cleandrive TPU	White	10,5	30	0,26	50	86	EU/FDA	box	43
PNH-30C	PNF/M-30XC	Cleandrive TPU	Cobalt blue	10,5	30	0,14	50	86	EU/FDA	box	100
PNH-60C	PNF/M-60XC	Cleandrive TPU	Cobalt blue	10,5	30	0,26	50	86	EU/FDA	box	43

Habiring are moulded polyurethane rings of 85 ShA. Available in different dimensions.

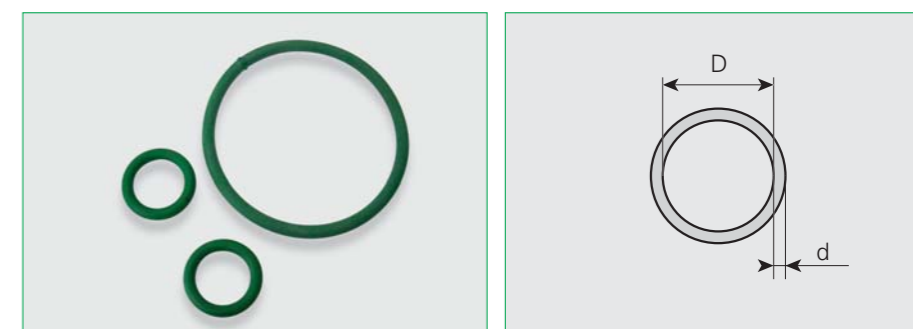

DESCRIPTION	d Diameter round belt (mm)	Medium length (mm)	weight (g)	D Inside diameter (mm)
HABIRING GREEN 2X118	2,00	118	4,00	35,5
HABIRING GREEN 2X128	2,00	128	4,00	38,7
HABIRING GREEN 2X147	2,00	147	4,50	44,8
HABIRING BLUE 2,5X78	2,50	78	3,50	22,3
HABIRING GREEN 2,5X78	2,50	78	3,50	22,3
HABIRING BLUE 2,75X268	2,75	268	7,00	82,8
HABIRING BLUE 2,75X307	2,75	307	8,50	95,2
HABIRING GREEN 3X140	3,00	140	4,95	41,6
HABIRING GREEN 3X155	3,00	155	5,45	46,3
HABIRING GREEN 3X161	3,00	161	5,65	48,2
HABIRING GREEN 3X175	3,00	175	5,80	52,7
HABIRING GREEN 3X245	3,00	245	7,00	75,0
HABIRING GREEN 3X374	3,00	374	15,50	116,0
HABIRING GREEN 3X277	3,00	377	16,50	117,0
HABIRING GREEN 3,2X100	3,20	100	4,60	28,6
HABIRING GREEN 3,2X133	3,20	133	5,25	39,1
HABIRING TRANSPARENT 3,5X207	3,50	207	7,10	62,4
HABIRING GREEN 4X112	4,00	112	5,50	31,7
HABIRING GREEN 4X122	4,00	122	5,60	34,8
HABIRING BLUE 4X258	4,00	258	5,80	78,12
HABIRING GREEN 5X123	5,00	123	7,00	34,1
HABIRING GREEN 5X182	5,00	182	8,80	52,9
HABIRING GREEN 5X196	5,00	196	9,20	57,4
HABIRING GREEN 6X95	6,00	95	7,00	24,2
HABIRING GREEN 6X119	6,00	119	8,00	31,9
HABIRING GREEN 6X130	6,00	130	8,50	35,4
HABIRING GREEN 6X142	6,00	142	9,00	39,2
HABIRING GREEN 6X200	6,00	200	11,50	57,7
HABIRING GREEN 6,5X11X445	6,50	445	4,35	135,1
HABIRING GREEN 7X119	7,00	119	9,00	30,9
HABIRING GREEN 7X128	7,00	128	9,50	33,7
HABIRING GREEN 7X130	7,00	130	10,50	34,38
HABIRING GREEN 7X170	7,00	170	12,50	47,1
HABIRING GREEN 7X173	7,00	173	12,70	48,1
HABIRING GREEN 7X385	15,00	385	106,00	107,5

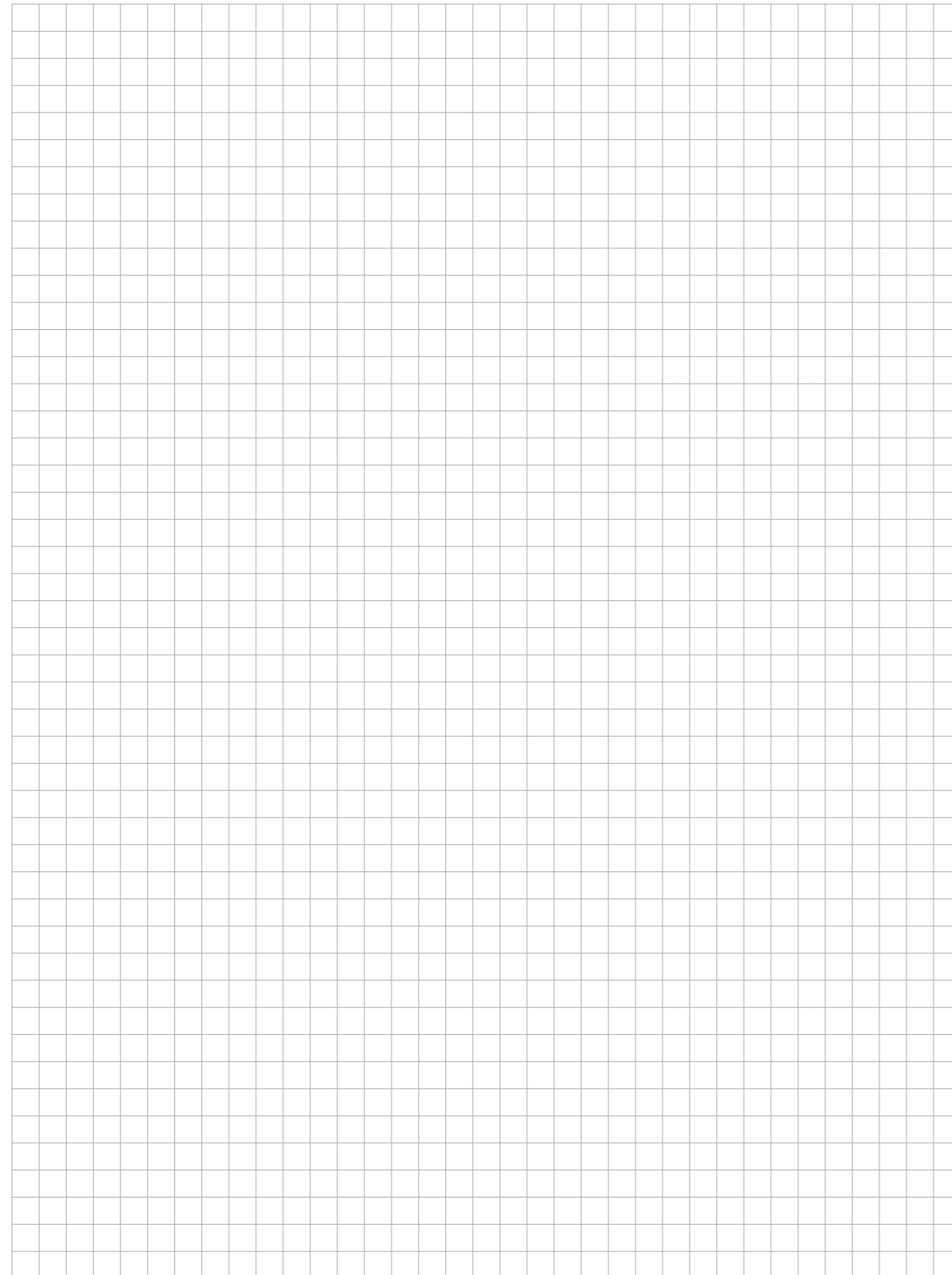

Customers first

At Habasit we understand that our success depends on your success. This is why we offer solutions, not just products; partnership, not just sales. Since our foundation in 1946, Habasit has brought this understanding of customer needs to life every day and for every application. That's why we're the No. 1 in belting today. Worldwide. Learn more on www.habasit.com

Committed to innovation

Habasit is strongly committed to the continuous development of innovative, value-added solutions. Over 3% of our staff are dedicated exclusively to R&D, and our annual investment in this area exceeds 8% of turnover.

Certified for quality

We deliver the highest quality standards not only in our products and solutions, but also in our employees' daily work processes. Habasit AG is certified according to ISO 9001:2000.



Worldwide leading product range

Habasit offers the largest selection of belting, conveying, processing and complementary products in the industry. Our response to any request is nothing less than a specific, tailor-made solution.

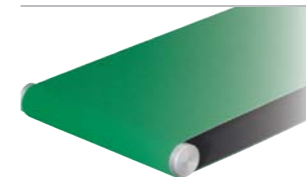

Fabric based conveyor and processing belts
HabaFLOW®

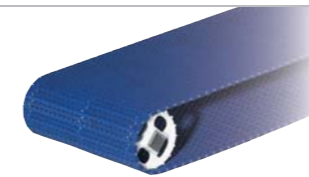

Plastic modular belts
HabasitLINK®/KVP®

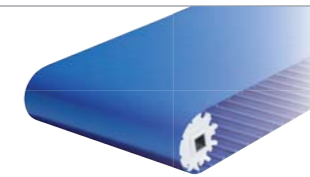

Positive drive conveyor and processing belts
Habasit Cleandrive™

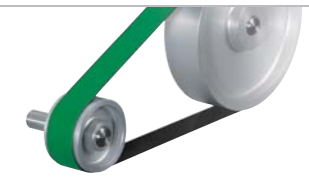

Power transmission belts
HabaDRIVE®



Timing belts
HabaSYNC®



Chains (slat and conveyor chains)
HabaCHAIN®



Machine tapes

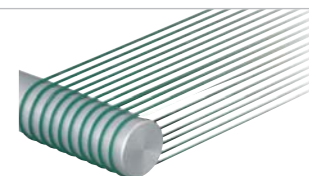

Round belts



Seamless belts



Profiles, Guides, Wear strips
HabiPLAST®



Fabrication tools (joining tools)



Gearmotors
Electric motors
Motion control

Austria

Habasisit GmbH, Wien
Phone: +43 1 690 66
www.habasisit.at

Belgium

Habasisit Belgium N.V., Zaventem
Phone: +32 2 725 04 30
www.habasisit.be

Canada

Habasisit Canada Ltd., Oakville
Phone: +1 905 827 4131
www.habasisit.ca

China

Habasisit East Asia Ltd., Hong Kong
Phone: +852 2145 01 50
www.habasisit.com.hk

Habasisit (Shanghai) Co., Ltd.
Shanghai

Phone: +8621 5488 1228
Phone: +8621 5488 1218
www.habasisit.com.hk

France

Habasisit France S.A.S., Mulhouse
Phone: +33 389 33 89 03
www.habasisit.fr

Germany

Habasisit GmbH
Eppertshausen
Phone: +49 6071 969 0
www.habasisit.de

Hungary

Habasisit Hungária Kft., Esztergom
Phone: +36 33 510 610
www.habasisit.hu

India

Habasisit-lakoka Pvt. Ltd., Coimbatore
Phone: +91 422 262 78 79
www.habasisitiakoka.com

Italy

Habasisit Italiana SpA
Customer Care:
Phone: 199 199 333
For int. calls: +39 0438 911444
www.habasisit.it

Japan

Habasisit Nippon Co. Ltd., Yokohama
Phone: +81 45 476 03 71
www.habasisit.co.jp

Netherlands

Habasisit Netherlands BV, Nijkerk
Phone: +31 33 24 72 030
www.habasisit.nl

New Zealand

Habasisit Australasia Ltd., Hornby
Phone: +64 3348 5600
www.habasisit.co.nz

Norway

Habasisit Norge A/S, Oslo
Phone: +47 81 55 84 58
www.habasisit.no

Poland

Habasisit Polska Sp. zo.o.,
Dąbrowa Górnicza,
Phone: +48 32 639 02 40
www.habasisit.pl

Romania

Habasisit Import/Export Romania SRL,
Bucuresti, Phone: +40 21 323 95 65
www.habasisit.ro

Russia

OOO Habasisit Ltd., St. Petersburg
Phone: +7 812 325 40 82
www.habasisit.ru

Singapore

Habasisit Far East Pte. Ltd., Singapore
Phone: +65 6862 55 66
www.habasisit.com.sg

Spain

Habasisit Hispanica S.A.,
Barberà del Vallès
Phone: +34 93 719 19 12
www.habasisit.es

Sweden

Habasisit AB, Hindas
Phone: +46 301 226 00
www.habasisit.se

Switzerland

Habasisit GmbH, Reinach
Phone: +41 61 577 51 00
www.habasisit.ch

Taiwan

Habasisit Rossi (Taiwan) Ltd.
Taipei Hsien
Phone: +886 2 2267 0538
www.habasisit.com.tw

Turkey

Habasisit Kayis San. Ve Tic. Ltd. Sti.
Yenibosna - Bahcelievler - Istanbul
Phone: +90-212-654 94 04
www.habasisit.com.tr

Ukraine

Habasisit Ukraina, Vinnica
Phone: +38 0432 58 47 35
www.habasisit.ua

United Kingdom and Ireland

Habasisit Rossi (UK) Ltd., Silsden
Phone: +44 870 835 9555
www.habasisitrossi.co.uk

USA

Habasisit America
Conveyor belts, power
transmission belts, gearmotors
Suwanee, Georgia
Phone: +1 800-458-6431
www.habasisitamerica.com

Habasisit America
Seamless belts, timing belts
Middletown, Connecticut
Phone: +1 860 632 2211
www.seamlessbelts.com
www.habasisync.com

Rossi is one of Europe's largest manufacturers of gear reducers, gearmotors, inverters, standard and brakemotors, and is a member of the Habasisit Group.

Rossi S.p.A.
Via Emilia Ovest 915/A
41100 Modena – Italy
Phone: +39 059 33 02 88
www.rossi-group.com
info@rossi-group.com

Headquarters

Habasisit AG
Römerstrasse 1
CH-4153 Reinach, Switzerland
Phone +41 61 715 15 15
Fax +41 61 715 15 55
E-mail info@habasisit.com
www.habasisit.com

Registered trademarks
Copyright Habasisit AG
Subject to alterations
Printed in Switzerland
Publication data:
4299BRO.PRF-en0611ITA